

Frequency converters

# VLT® 2800



## Metasys N2 Instruction Manual



VLT® is a trademark of Danfoss A/S

** DANGER**

**Rotating shafts and electrical equipment can be hazardous. Therefore, it is strongly recommended that all electrical work conform to National Electrical Code (NEC) and all local regulations. Installation, start-up and maintenance should be performed only by qualified personnel.**

Factory recommended procedures, included in this manual, should be followed. Always disconnect electrical power before working on the unit.

Although shaft couplings or belt drives are generally not furnished by the manufacturer, rotating shafts, couplings and belts must be protected with securely mounted metal guards that are of sufficient thickness to provide protection against flying particles such as keys, bolts and coupling parts. Even when the motor is stopped, it should be considered “alive” as long as its controller is energized. Automatic circuits may start the motor at any time. Keep hands away from the output shaft until the motor has completely stopped and power is disconnected from the controller.

Motor control equipment and electronic controls are connected to hazardous line voltages. When servicing drives and electronic controls, there will be exposed components at or above line potential. Extreme care should be taken to protect against shock. Stand on an insulating pad and make it a habit to use only one hand when checking components. Always work with another person in case of an emergency. Disconnect power whenever possible to check controls or to perform maintenance. Be sure equipment is properly grounded. Wear safety glasses whenever working on electric control or rotating equipment.

**Safety Guidelines**

1. The drive must be disconnected from the AC line before any service work is done.
2. The “Stop/Off” key on the local control panel of the drive does not disconnect the equipment from the AC line and is not to be used as a safety switch.
3. Correct protective grounding of the equipment must be established. The user must be protected against supply voltage and the motor must be protected against overload in accordance with applicable national and local regulations.
4. Ground currents are higher than 3 mA.

**Warnings Against Unintended Start**

1. While the drive is connected to the AC line, the motor can be brought to a stop by means of external switch closures, serial bus commands or references. If personal safety considerations make it necessary to ensure that no unintended start occurs, these stops are not sufficient.
2. During programming of parameters, the motor may start. Be certain that no one is in the area of the motor or driven equipment when changing parameters.
3. A motor that has been stopped may start unexpectedly if faults occur in the electronics of the drive, or if an overload, a fault in the supply AC line or a fault in the motor connection or other fault clears.
4. If the “Local/Hand” key is activated, the motor can only be brought to a stop by means of the “Stop/Off” key or an external safety interlock.

**NOTE**

**It is responsibility of user or person installing drive to provide proper grounding and branch circuit protection for incoming power and motor overload according to National Electrical Code (NEC) and local codes.**

The Electronic Thermal Relay (ETR) in UL listed VLTs provides Class 20 motor overload protection in accordance with NEC in single motor applications, when parameter 117 is set for “ETR TRIP 1”, “ETR TRIP 2”, “ETR TRIP 3”, or “ETR TRIP 4”, and parameter 105 is set for rated motor (nameplate) current.

** DANGER**

**Touching electrical parts may be fatal – even after equipment has been disconnected from AC line. To be sure that capacitors have fully discharged, wait 14 minutes after power has been**

©Copyright 2001, Danfoss Graham



## Table of Contents

Introduction .....	4
About This Manual .....	4
References .....	4
Trademarks .....	4
Abbreviations and Definitions .....	5
Network Connection .....	6
Control Wiring and Terminal Tightening Torques Specifications .....	6
Error Codes .....	7
VLT 2800 N2 Startup .....	7
General Commands (Acknowledged) .....	8
General Commands (Not Acknowledged) .....	8
Analog Input (AI) Commands (Acknowledged) .....	9
Analog Input (AI) Commands (Not Acknowledged) .....	10
Analog Output (AO) Commands (Acknowledged) .....	11
Analog Output (AO) Commands (Not Acknowledged) .....	12
Binary Input (BI) Commands (Acknowledged) .....	13
Binary Input (BI) Commands (Not Acknowledged) .....	14
Binary Output (BO) Commands (Acknowledged) .....	15
Binary Output (BO) Commands (Not Acknowledged) .....	16
Internal Integers (ADI) Commands (Acknowledged) .....	17
Internal Floating Point (ADF) Commands (Acknowledged) .....	17
APPENDIX A: Metasys Point Mapping Tables	
Analog Inputs (AI) .....	18
Binary Inputs (BI) .....	19
Analog Outputs (AO) .....	21
Binary Outputs (BO) .....	21
Internal Floating Points (ADF) .....	22
Internal Integers (ADI) .....	23

**■ Introduction**

The VLT® 2800 control board is program selectable for use with the Johnson Controls Metasys N2 protocol. Metasys N2 is a master/slave control network. The physical layer is RS-485 compatible, half duplex 9600 baud shielded twisted pair. The N2 software protocol is designed to be general in nature to accommodate the unique properties each device type may have. Every device connection to the N2 network can be thought of as a small data manager. Data points in the database are classified as analog I/O (floating point), binary I/O or integer data points - floats, integers or bytes. Each data type has its own unique structure defined in the Metasys N2 system Protocol Specification for Vendors.

The information in this manual is intended to provide information on set up for VLT communication over a Metasys network.

For specific information on operation of the drive, refer to the *VLT 2800 Operating Instructions*.

**■ About This Manual**

This manual is for both instructional and for reference purposes. This manual can also serve as a guideline when you specify and optimize your communication system.

It is highly recommended that you read this manual in its entirety before initiating any programming. It is assumed that the user has full knowledge of the capabilities and limitation of the controller node in addition to full knowledge of the VLT 2800 drive.

**■ References**

In addition to this manual, the following two manuals should be referenced:

*VLT 2800 Operating Instructions*, Danfoss document number MG28Axxx.

*Johnson Controls METASYS N2 System Protocol Specification for Vendors*, Johnson Controls number 04-3402-22.

**■ Trademarks**

METASYS® N2 is a Johnson Controls Inc registered trademark.

VLT® is a Danfoss registered trademark.

**■ Abbreviations and Definitions**

ACK	Acknowledged
ADF	Internal Floating Points
ADI	Internal Integers
AI	Analog Inputs (From the drive to the N2 bus.)
AO	Analog Outputs (From the N2 bus to the drive.)
BI	Binary Inputs (From the drive to the N2 bus.)
BO	Binary Outputs (From the N2 bus to the drive.)
COS	Change of State
HPFB	High Performance Field Bus
JCI	Johnson Controls Inc., developers of the METASYS N2 protocol.
N2	METASYS N2
N2 master	An N2 master is either a PC with JCI software or a dedicated JCI controller.
NAK	Not acknowledged
NPA	N2 Point Address (Each N2 Point Type has a address range from 1 to 255, or 0 to 254.)
NPT	N2 Point Type
Par.	Parameter Number

■ **Network Connection**

Connect signal wires (N2+) to terminal 68 and (N2-) to terminal 69 on main control board of the drive. (See figure below.) It is highly recommended to use shielded, twisted-pair cables to reduce the differential mode interference between the conductors. Observe standard shielding practice by grounding the shielded wiring (S) at only one point in the system. The Metasys reference wire (REF) may be connected to terminal 70, but this is not necessary.

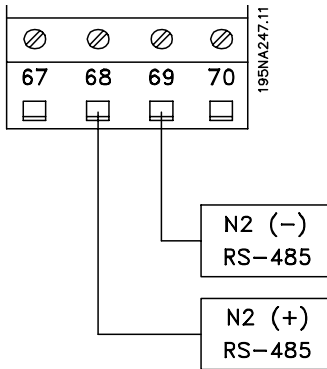

Figure 1. Network Connection

■ **Control Wiring and Terminal Tightening Torque Specifications**

Terminal tightening and control wire specifications are defined in the table below.

Torque Specs	4.5 in lb/0.5 Nm
Control Wire	18 - 24 AWG, shielded, twisted pair/1.5 mm, shielded twisted pair

**■ Error Codes**

Error Code 00 is issued after power-up or after a time out where all overridden points were released, as long as no Identify Yourself command has been issued by the master.

Error Code 01 is issued if the command is not supported or not known by the drive.

Error Code 02 is issued if the received telegram has a checksum error.

Error Code 03 is issued if the N2 telegram receive buffer exceeds 256 characters.

Error Code 05 is issued if the received N2 telegram is too long.

Error Code 10 is issued if the data is out of the expected range.

Error Code 11 is issued when:

1. A point attributes or attribute bit is unused.
2. A point attributes or attribute bit is for JCI use only.
3. An internal data point attribute cannot be changed while running.

Error Code 12 is issued when:

1. The N2 master tries to change attribute 2 bit 6 "Current State" on a BO and the drive is tripped.
2. The N2 master tries to change attribute 2 bit 6 "Current State" on a BO and the drive is tripped except for BO 5 "reset."

**■ VLT 2800 N2 Startup**

Use the VLT 2800 keypad, mounted either on the drive or with the optional remote Local Control Panel 2 (LCP 2), to access Menu Mode and the 500 Group (serial communication) parameters. To enter Menu Mode through the VLT 2800 keypad, press the [Quick Menu] and [+] keys at the same time. Use the [+] and [-] keys to scroll through parameters.

Set parameters 561, 500, and 501 as shown in the startup serial communications table below. Other settings may be changed to meet application requirements. The settings shown will serve as a good starting reference. Refer to the *VLT 2800 Operating Instructions* for details on changing parameters and programming the drive.

Parameter 560, N2 Override Release Time, selects the maximum time between receiving two N2 messages. The interval is 1 to 65,534 seconds (off). If the interval is exceeded, serial communication is assumed stopped. All N2 points which are overridden are released in the following order: analog outputs, binary outputs, internal float points, internal integer points, and internal byte points. The points are released in numerical order starting with point 1 (or 0).

**N2 Serial Communication Startup Parameter Settings**

<b>Parameter</b>	<b>Name</b>	<b>Setting</b>
500	Address	<b>001</b>
501	Baud rate	<b>9600 BAUD</b> (fixed at 9600 for N2 protocol)
502	Coasting	<b>LOGIC OR</b>
503	Quick stop	<b>LOGIC OR</b>
504	DC brake	<b>LOGIC OR</b>
505	Start	<b>LOGIC OR</b>
506	Reversing	<b>LOGIC OR</b>
507	Select setup	<b>LOGIC OR</b>
508	Select speed	<b>LOGIC OR</b>
560	N2 Override release time	<b>OFF</b>
561	Protocol	<b>METASYS N2</b>

The values in bold are default values.



### General Commands (Acknowledged)

VLT Response	Command	Subcommand	Region	NPA Object no.	Attribute Number	Attribute Type	Message	Error Code	Comments
ACK	0	4	-	-	-	-	Poll Message No Acknowledge	-	The slave is to respond with any data points, analog or binary I/O that have been flagged for COS.
ACK	0	5	-	-	-	-	Poll message With Acknowledge	-	The slave is to respond with any data points, analog or binary I/O that have been flagged for COS.
ACK	0	9	-	-	-	-	Status update Message	-	Slave device must respond with device manufacturing model number (Par. 621), days in service (Par. 600) and device status.
ACK	F	-	-	-	-	-	Identify Device Type	-	Slave device responds with an identification number of 10H to indicate non JCI device.
ACK, no action	0	0	-	-	-	-	Synch Time	-	No internal clock is available on the basic control card.
ACK, no action	8	0	-	-	-	-	Upload	-	Optional, not support in VLT 2800 N2
ACK, no action	8	1	-	-	-	-	Upload	-	Optional, not support in VLT 2800 N2
ACK, no action	8	3	-	-	-	-	Upload Record	-	Optional, not support in VLT 2800 N2
ACK, no action	8	4	-	-	-	-	Upload Complete	-	Optional, not support in VLT 2800 N2
ACK, no action	9	0	-	-	-	-	Download	-	Optional, not support in VLT 2800 N2
ACK, no action	9	1	-	-	-	-	Download	-	Optional, not support in VLT 2800 N2
ACK, no action	9	3	-	-	-	-	Download Record	-	Optional, not support in VLT 2800 N2
ACK, no action	9	4	-	-	-	-	Download Complete	-	Optional, not support in VLT 2800 N2

### General Commands (Not Acknowledged)

NAK	0	1	-	-	-	-	Read Memory	01	Slave device memory read based on memory addresses.
NAK	0	8	-	-	-	-	Warm Start	01	JCI use only.

Analog Input (AI) Commands (Acknowledged)

VLT Response	Command	Subcommand	Region	NPA Object no.	Attribute number	Attribute Type	Message	Error Code	Comments
ACK	1	-	1	1-24	1	Byte	Read Analog Input	-	Read Object Configuration attribute associated with each individual point.
ACK	1	-	1	1-24	2	Byte	Read Analog Input	-	1) Read Object Status attribute associated with each individual point.
ACK	1	-	1	1-24	3	Float	Read Analog Input	-	2) Read Analog Input Value attribute associated with each individual point.
ACK	1	-	1	1-24	8	Float	Read Analog Input	-	Read Low Alarm attribute associated with each individual point.
ACK	1	-	1	1-24	9	Float	Read Analog Input	-	Read Low Warning attribute associated with each individual point.
ACK	1	-	1	1-24	10	Float	Read Analog Input	-	Read High Warning attribute associated with each individual point.
ACK	1	-	1	1-24	11	Float	Read Analog Input	-	Read High Alarm attribute associated with each individual point.
ACK	1	-	1	1-24	12	Float	Read Analog Input	-	Read Differential attribute associated with each individual point.
ACK	2	-	1	1-24	1	Byte	Write Analog Input	-	Write to Object Configuration attribute associated with each individual point.
ACK	2	-	1	1-24	8	Float	Write Analog Input	-	Write to Low Alarm Limit attribute associated with each individual point.
ACK	2	-	1	1-24	9	Float	Write Analog Input	-	Write to Low Warning Limit attribute associated with each individual point.
ACK	2	-	1	1-24	10	Float	Write Analog Input	-	Write to High Warning Limit attribute associated with each individual point.
ACK	2	-	1	1-24	11	Float	Write Analog Input	-	Write to High Alarm Limit attribute associated with each individual point.
ACK	2	-	1	1-24	12	Float	Write Analog Input	-	Write to Differential attribute associated with each individual point.
ACK, no action	7	2	1	1-24	-	Float	Override Analog Input	-	Analog inputs are “outputs” from the VLT 2800 and should not be written over by the network controller.
ACK, no action	7	3	1	1-24	-	-	Override Release	-	Analog inputs are “outputs” from the VLT 2800 and should not be written over by the network controller.
ACK, no action	7	7	1	1-24	-	-	Write Analog Input Attributes	-	Optional command for slave devices. Only used for N2 commissioning purposes.
ACK, no action	7	8	1	1-24	-	-	Read Analog Input Attributes	-	Optional command for slave devices. Only used for N2 commissioning purposes. Not to be implemented at this time.

Analog Input (AI) Commands (Not Acknowledged)

VLT Response	Command	Subcommand	Region	NPA Object no.	Attribute Number	Attribute Type	Message	Error Code	Comments
NAK	1	-	1	1-24	4	Float	Read Analog Input	11	Read Linear Ranging Parameter 1 attribute associated with each individual point. (JCI use only)
NAK	1	-	1	1-24	5	Float	Read Analog Input	11	Read Linear Ranging Parameter 2 attribute associated with each individual point. (JCI use only)
NAK	1	-	1	1-24	6	Float	Read Analog Input	11	Read Linear Ranging Parameter 3 attribute associated with each individual point. (JCI use only)
NAK	1	-	1	1-24	7	Float	Read Analog Input	11	Read Linear Ranging Parameter 4 attribute associated with each individual point. (JCI use only)
NAK	1	-	1	1-24	13	Integer	Read Analog Input	11	Read Filter Weight attribute associated with each individual point. (JCI use only)
NAK	1	-	1	1-24	14	Float	Read Analog Input	11	Read AI_Offset attribute associated with each individual point. (JCI use only)
NAK	2	-	1	1-24	2	Byte	Write Analog Input	11	Object Status not writeable.
NAK	2	-	1	1-24	3	Float	Write Analog Input	11	Analog Input Value not writeable.
NAK	2	-	1	1-24	4	Float	Write Analog Input	11	Write to Linear Ranging Parameter 1 attribute associated with each individual point. (JCI use only)
NAK	2	-	1	1-24	5	Float	Write Analog Input	11	Write to Linear Ranging Parameter 2 attribute associated with each individual point. (JCI use only)
NAK	2	-	1	1-24	6	Float	Write Analog Input	11	Write to Linear Ranging Parameter 3 attribute associated with each individual point. (JCI use only)
NAK	2	-	1	1-24	7	Float	Write Analog Input	11	Write to Linear Ranging Parameter 4 attribute associated with each individual point. (JCI use only)
NAK	2	-	1	1-24	13	Integer	Write Analog Input	11	Write to Filter Weight attribute associated with each individual point. (JCI use only)
NAK	2	-	1	1-24	14	Float	Write Analog Input	11	Write to AI Offset attribute associated with each individual point. (JCI use only)

Error code 11 is used because attributes are considered as fields/records in the point map database.

**Analog Output (AO) Commands (Acknowledged)**

VLT Response	Command	Subcommand	Region	NPA Object no.	Attribute Number	Attribute Type	Message	Error Code	Comments
ACK	1	-	3	1-2	1	Byte	Read Analog Output	-	Read Object Configuration attribute associated with each individual point.
ACK	1	-	3	1-2	2	Byte	Read Analog Output	-	Read Object Status attribute associated with each individual point.
ACK	1	-	3	1-2	3	Float	Read Analog Output	-	Read Current Value attribute associated with each individual point.
ACK	2	-	3	1-2	1	Byte	Write Analog Output	-	Write to Object Configuration attribute associated with each individual point.
ACK	7	2	3	1-2	-	Float	Override Analog Output	-	Write to analog output current value (frequency setpoint).
ACK	7	3	3	1-2	-	-	Override Release	-	Set the current value, the value that it was before the 1. Override Command was issued
ACK, no action	7	7	3	1-2	-	-	Write Analog Output Attributes	-	Optional command for slave devices. Only used for N2 commissioning purposes. Not to be implemented at this time.
ACK, no action	7	8	3	1-2	-	-	Read Analog Output Attributes	-	Optional command for slave devices. Only used for N2 commissioning purposes. Not to be implemented at this time.

Analog Output (AO) Commands (Not Acknowledged)

VLT Response	Command	Subcommand	Region	NPA Object no.	Attribute Number	Attribute Type	Message	Error Code	Comments
NAK	1	-	3	1-2	4	Float	Read Analog Output	11	Read Low Linear Ranging Parameter attribute associated with each individual point.(JCI use only)
NAK	1	-	3	1-2	5	Float	Read Analog Output	11	Read High Linear Ranging Parameter attribute associated with each individual point.(JCI use only)
NAK	2	-	3	1-2	2	Byte	Write Analog Output	11	Object Status not writeable.
NAK	2	-	3	1-2	3	Float	Write Analog Output	11	Write to Current Value structure attributes associated with each individual point. (N2 does not support this, override function must be used)
NAK	2	-	3	1-2	4	Float	Write Analog Output	11	Write Debouncing Value in msec attribute associated with each individual point. (JCI use only)
NAK	2	-	3	1-2	5	Float	Write Analog Output	11	Write Accumulator value attribute associated with each individual point. (JCI use only)

Error code 11 is used because attributes are considered as fields/records in the point map database.

**Binary Input (BI) Commands (Acknowledged)**

VLT Response	Command	Subcommand	Region	NPA Object no.	Attribute Number	Attribute Type	Message	Error Code	Comments
ACK	1	-	2	1-72	1	Byte	Read Binary Input	-	Read Object Configuration attribute associated with each individual point.
ACK	1	-	2	1-72	2	Byte	Read Binary Input	-	Read Object Status attribute associated with each individual point.
ACK	2	-	2	1-72	1	Byte	Write Binary Input	-	Write to Object Configuration attribute associated with each individual point.
ACK, no action	7	2	2	1-72	-	Byte(0/1)	Override Binary Input	-	Binary inputs are “outputs” from the VLT 6000 and should not be written over by the network controller. (Status word, Warnings, and Alarms)
ACK no-action	7	3	2	1-72	-	-	Override Release	-	Binary inputs are “outputs” from the drive and should not be written over by the network controller. (Status word, Warnings, and Alarms)
ACK, no action	7	7	2	1-72	-	-	Write Binary Input Attributes	-	Optional command for slave devices. Only used for N2 commissioning purposes. Not to be implemented at this time.
ACK, no action	7	8	2	1-72	-	-	Read Binary Input Attributes	-	Optional command for slave devices. Only used for N2 commissioning purposes. Not to be implemented at this time.

Binary Input (BI) Commands (Not Acknowledged)

VLT Response	Command	Subcommand	Region	NPA Object no.	Attribute Number	Attribute Type	Message	Error Code	Comments
NAK	1	-	2	1-72	3	Integer	Read Binary Input	11	Read Debouncing Value in Msec attribute associated with each individual point. (JCI use only)
NAK	1	-	2	1-72	4	Integer 32	Read Binary Input	11	Read Accumulator Value attribute associated with each individual point. (JCI use only)
NAK	2	-	2	1-72	2	Byte	Write Binary Input	11	Object Status not writeable.
NAK	2	-	2	1-72	3	Integer	Write Binary Input	11	Write Debouncing Value in msec attribute associated with each individual point. (JCI use only)
NAK	2	-	2	1-72	4	Integer 32	Write Binary Input	11	Write Accumulator value attribute associated with each individual point.(JCI use only)

Error code 11 is used because attributes are considered as fields/records in the point map database.

Binary Output (BO) Commands (Acknowledged)

VLT Response	Command	Subcommand	Region	NPA Object No.	Attribute Number	Attribute Type	Message	Error Code	Comments
ACK	1	-	4	1-9	1	Byte	Read Binary Output	-	Read structure attributes associated with each individual point.
ACK	1	-	4	1-9	2	Byte	Read Binary Output	-	Read structure attributes associated with each individual point.
ACK	2	-	4	1-9	1	Byte	Write Binary Output	-	Write to Object Configuration attribute associated with each individual point.
ACK	7	2	4	1-9	-	Byte (0/1)	Override Binary Output	-	Write to binary output current state (Tech 500 control word).
ACK	7	3	4	1-9	-	-	Override Release	-	Set the current value, the value that it was before the 1. Override Command was issued
ACK no action	1	-	4	1-9	3	Integer	Read Binary Output	-	Read Minimum On-time attribute associated with each individual point. <b>Return value = 0</b>
ACK no action	1	-	4	1-9	4	Integer	Read Binary Output	-	Read Minimum Off-time attribute associated with each individual point. <b>Return value = 0</b>
ACK no action	1	-	4	1-9	5	Integer	Read Binary Output	-	Read Maximum Cycles/Hour attribute associated with each individual point. <b>Return value = 0</b>
ACK no action	2	-	4	1-9	3	Integer	Write Binary Output	-	Write Minimum On-time attribute associated with each individual point.
ACK no action	2	-	4	1-9	4	Integer	Write Binary Output	-	Write Minimum Off-time attribute associated with each individual point.
ACK no action	2	-	4	1-9	5	Integer	Write Binary Output	-	Write Maximum Cycles/Hour attribute associated with each individual point.
ACK, no action	7	7	4	1-9	-	-	Write Binary Output Attributes	-	Optional command for slave devices. Only used for N2 commissioning purposes.
ACK, no action	7	8	4	1-9	-	-	Read Binary Output Attributes	-	Optional command for slave devices. Only used for N2 commissioning purposes.



Binary Output (BO) Commands (Not Acknowledged)

VLT Response	Command	Subcommand	Region	NPA Object no.	Attribute Number	Attribute Type	Message	Error Code	Comments
NAK	1	-	4	1-9	6	Integer	Read Binary Output	11	Read Interstage on delay attribute associated with each individual point. (JCI use only)
NAK	1	-	4	1-9	7	Integer	Read Binary Output	11	Read Interstage off delay attribute associated with each individual point. (JCI use only)
NAK	2	-	4	1-9	2	Byte	Write Binary Output	11	Object Status not writeable.
NAK	2	-	4	1-9	6	Integer	Write Binary Output	11	Write Interstage on delay attribute associated with each individual point. (JCI use only)
NAK	2	-	4	1-9	7	Integer	Write Binary Output	11	Write Interstage off delay attribute associated with each individual point. (JCI use only)

Error code 11 is used because attributes are considered as fields/records in the point map.

Internal Integers (ADI) Commands (Acknowledged)

VLT Response	Command	Subcommand	Region	NPA Object no.	Attribute Number	Attribute Type	Message	Error Code	Comments
ACK	1	-	6	1	1	Byte	Read Internal Parameter of object type integer (16 bit)	-	Read Object Status attribute associated with each individual point.
ACK	1	-	6	1	2	Integer	Read Internal Parameter of object type integer (16 bit)	-	Read Current Value attribute associated with each individual point.
ACK	2	-	6	1	-	Integer	Write Internal Parameter of object type integer (16 bit)	-	Write Current Value attribute associated with each individual point.
ACK	7	2	6	1	-	Integer	Override Internal Parameter of object type integer (16 bit)	-	Write to Internal Parameter current value (setup parameter for VLT)
ACK	7	3	6	1	-	-	Override Release	-	Set the current value, the value that it was before 1. Override Command was issued.

Internal Floating Point (ADF) Commands (Acknowledged)

VLT Response	Command	Subcommand	Region	NPA Object No.	Attribute Number	Attribute Type	Message	Error Code	Comments
ACK	1	-	5	1-42	1	Byte	Read Internal Parameter of object type float	-	Read Object Status attribute associated with each individual point
ACK	1	-	5	1-42	2	Float	Read Internal Parameter of object type float	-	Read Current Value attribute associated with each individual point
ACK	2	-	5	1-42	-	Float	Write Internal Parameter of object type float	-	Write to Current Value attribute associated with each individual point.
ACK	2	-	5	1-42	-	Float	Write Internal Parameter of object type float	-	Write to Current Value attribute associated with each individual point.
ACK	7	2	5	1-42	-	Float	Override Internal Parameter of object type float	-	Write to internal parameter current value (set-up parameters for VLT).
ACK	7	3	5	1-42	-	-	Override Release	-	Set the current value, the value that it was before the 1. Override Command was issued

## Appendix A

### METASYS POINT MAPPING TABLES

#### NOTE

Some Metasys software use an object number range from 1 to 255. Other Metasys software use the range 0 to 254. The second type software will interpret object number 1 as 0, 2 as 1, and so on. To access the proper point with that type Metasys software, subtract 1 from each NPA number in these tables.

The default values on the following pages are shown in **BOLD**.

Any point not listed on the following pages is reserved for future use.

#### Analog Inputs (AI)

NPT	NPA	UNIT	Description	Range	VLT 2800 PNU
AI	1	%	Reference	-	515
AI	2	Hz, rpm	Reference	-	516
AI	3	Par. 416	Feedback [Unit]	-	517
AI	4	Hz	Frequency	-	518
AI	5	Hz	Frequency x Scale	-	519
AI	6	Amp	Motor current	-	520
AI	7	kW	Power	-	522
AI	8	HP	Power	-	523
AI	9	V	Motor voltage	-	524
AI	10	V	DC link voltage	-	525
AI	11	%	Thermal load motor	-	526
AI	12	%	Thermal load inverter	-	527
AI	13	V	Terminal 53 analog	-	529
AI	14		Reserved		
AI	15	mA	Terminal 60 analog	-	531
AI	16	Hz	Pulse reference	-	532
AI	17	%	External reference	-	533
AI	18	C	Inverter temperature	-	537
AI	19	Hour	Operating hours	-	600
AI	20	Hour	Hours run	-	601
AI	21	kWh	kWh counter	-	602
AI	22	-	Number of power-ups	-	603
AI	23	-	Number of over temps	-	604
AI	24	-	Number of over volts	-	605

Binary Inputs (BI)

NPT	NPA	UNIT	Description	Range	VLT 2800 PNU
BI	1	-	Thermal warning status	<b>0=OK</b> , 1=Limit	534
BI	2	-	Current limit status	<b>0=OK</b> , 1=Limit	534
BI	3	-	Voltage warning status	<b>0=OK</b> , 1=Limit	534
BI	4	-	Ramping	<b>0=FALSE</b> , 1=TRUE	541
BI	5	-	Motor running status	<b>0=Not Running</b> , 1=Running	534
BI	6	-	Frequency status	0=Out of Range, <b>1=In Range</b>	534
BI	7	-	Control status	0=Local, <b>1=Bus</b>	534
BI	8	-	Reference status	0=Not on Ref., <b>1=On Ref.</b>	534
BI	9	-	Warning status	<b>0=No Warning</b> , 1= Warning	534
BI	10	-	Tripped status	<b>0=No Trip</b> , 1=Tripped	534
BI	11	-	Coasting stop status	0=Not Enabled, <b>1=Enabled</b>	534
BI	12	-	Drive ready status	0=Not Ready, <b>1=Ready</b>	534
	13	-	Drive control status	0=Not Ready, <b>1=Ready</b>	534
BI	14	-	Heat sink temperature high	<b>0=OK</b> , 1=Warning	540
BI	15	-	Switch mode warning	<b>0=OK</b> , 1=Warning	540
BI	16	-	Terminal 33	<b>0=NO SIGNAL</b> , 1=Signal	528
BI	17	-	Terminal 29	<b>0=NO SIGNAL</b> , 1=Signal	528
BI	18	-	Terminal 27	<b>0=NO SIGNAL</b> , 1=Signal	528
BI	19	-	Terminal 19	<b>0=NO SIGNAL</b> , 1=Signal	528
BI	20	-	Terminal 18	<b>0=NO SIGNAL</b> , 1=Signal	528
BI	21	-	Output frequency low	<b>0=FALSE</b> , 1=TRUE	541
BI	22	-	Output frequency high	<b>0=Remote ref.</b> , 1=Local ref.	541
BI	23	-	Output current low	<b>0=FALSE</b> , 1=TRUE	541
BI	24	-	Reserved		
BI	25	-	Out of frequency range	<b>0=OK</b> , 1=Warning	540
BI	26	-	Output current high	<b>0=FALSE</b> , 1=TRUE	541
BI	27	-	Feedback low	<b>0=FALSE</b> , 1=TRUE	541
BI	28	-	Feedback high	<b>0=FALSE</b> , 1=TRUE	541
BI	29	-	Reserved		
BI	30	-	Reserved		
BI	31	-	Live zero error	<b>0=OK</b> , 1=Warning	540

The values in bold are default values.

## Appendix A

**Binary Inputs (BI) - Continued**

BI	32	-	Phase loss	<b>0=OK, 1=Warning</b>	540
NPT	NPA	UNIT	Description	Range	VLT 2800 PNU
BI	34	-	Voltage warning low	<b>0=OK, 1=Warning</b>	540
BI	35	-	DC link over voltage	<b>0=OK, 1=Warning</b>	540
BI	36	-	DC link under voltage	<b>0=OK, 1=Warning</b>	540
BI	37	-	Inverter overload	<b>0=OK, 1=Warning</b>	540
BI	38	-	Motor overload	<b>0=OK, 1=Warning</b>	540
BI	39	-	Motor thermistor	<b>0=OK, 1=Warning</b>	540
BI	40	-	Current limit	<b>0=OK, 1=Warning</b>	540
BI	41	-	Reserved		
BI	42	-	Standard bus timeout	<b>0=OK, 1=Warning</b>	540
BI	43	-	Reserved		
BI	44	-	Reserved		
BI	45	-	Internal fault	<b>0=OK, 1=Alarm</b>	538
BI	46	-	Reserved		
BI	47	-	Reserved		
BI	48	-	Reserved		
BI	49	-	Reserved		
BI	50	-	Reserved		
BI	51	-	Reserved		
BI	52	-	Reserved		
BI	53	-	Reserved		
BI	54	-	Reserved		
BI	55	-	Reserved		
BI	56	-	Heat sink temperature too high	<b>0=OK, 1=Alarm</b>	538
BI	57	-	Live zero	<b>0=OK, 1=Alarm</b>	538
BI	58	-	Phase loss	<b>0=OK, 1=Alarm</b>	538
BI	59	-	Dc link over voltage	<b>0=OK, 1=Alarm</b>	538
BI	60	-	Dc link under voltage	<b>0=OK, 1=Alarm</b>	538
BI	61	-	Inverter overload	<b>0=OK, 1=Alarm</b>	538
BI	62	-	Motor overload	<b>0=OK, 1=Alarm</b>	538
BI	63	-	Motor thermistor	<b>0=OK, 1=Alarm</b>	538
BI	64	-	Reserved	<b>0=OK, 1=Alarm</b>	538
BI	65	-	Over current	<b>0=OK, 1=Alarm</b>	538
BI	66	-	earth fault	<b>0=OK, 1=Alarm</b>	538
BI	67	-	Switch mode fault	<b>0=OK, 1=Alarm</b>	538
BI	68	-	Short circuit	<b>0=OK, 1=Alarm</b>	538
BI	69	-	Std bus timeout	<b>0=OK, 1=Alarm</b>	538
BI	70	-	Reserved	<b>0=OK, 1=Alarm</b>	538
BI	71	-	AMT tuning fail	<b>0=OK, 1=Alarm</b>	538
BI	72	-	Trip lock	<b>0=Trip, 1=Trip lock</b>	538

The values in bold are default values.

## Appendix A

## Analog Outputs (AO)

NPT	NPA	UNIT	Description	Range	VLT 2800 PNU
AO	1	%	Bus reference	0% to 100% proportionally mapped into the range 0 to 16384	-
AO	2	%	Bus feedback 1	0% to 100% proportionally mapped into the range 0 to 16384	535

*Bus reference:* when parameter 100, *Configuration*, is set to Speed Open Loop [0], this is a speed reference from the drive. For example, to set 100% speed, set AO1 to 16384. In Speed Closed Loop [1] or Process Closed Loop [3] in parameter 100, bus reference is a setpoint. (The range may be exceeded by up to 200% to compensate for negative values used with external or preset references.)

*Bus feedback 1:* when parameter 100, *Configuration*, is set to Speed Closed Loop [1] or Process Closed Loop [3], this is a feedback signal to the PID controller.

## Binary Outputs (BO)

NPT	NPA	UNIT	Description	Range	VLT 2800 PNU
BO	1	-	DC brake inverse	0=Active, <b>1 = Not active</b>	-
BO	2	-	Coast inverse	0=Active, <b>1 = Not active</b>	-
BO	3	-	Stop inverse	0=Active, <b>1 = Not active</b>	-
BO	4	-	Freeze output inverse	0=Active, <b>1 = Not active</b>	-
BO	5	-	Start	<b>0= Not active</b> , 1 = Active	-
BO	6	-	Reset	<b>0= Not active</b> , 1 = Active	-
BO	7	-	Jog	<b>0= Not active</b> , 1 = Active	-
BO	8	-	Relay 01	<b>0= Not active</b> , 1 = Active	-
BO	9	-	Reverse	<b>0= Not active</b> , 1 = Active	-

The values in bold are default values.

**Internal Floating Point (ADF)**

NPT	NPA	UNIT	Description	Range	VLT 2800 PNU
ADF	1	-	Display scaling of output frequency	0.01 to 100	008
ADF	2	Unit	Minimum feedback	-100,000.000 to Max. feedback	414
ADF	3	Unit	Maximum feedback	Min. feedback to 100,000.000	415
ADF	4	Hz	Process PID start frequency	Min. feedback to Max feedback	439
ADF	5	-	Process PID proportional gain	0.00 to 10	440
ADF	6	Sec	Process PID integral time	0.01 to 9,999.99 (off)	441
ADF	7	Sec	Process PID differential time	0 (off) to 10	442
ADF	8	-	Process PID D-gain limit	5.0 to 50	443
ADF	9	Sec	Process PID lowpass filter time	0.02 to 10	444
ADF	10	Hz	Local reference	Varies with Local Control options	003
ADF	11	kW	Motor power	0.25 to 11	102
ADF	12	V	Motor voltage	50 to 999	103
ADF	13	Hz	Motor frequency	24 to 1000	104
ADF	14	A	Motor current	0.01 to Drive rating	105
ADF	15	RPM	Motor nom. speed	100 to 60,000	106
ADF	16	V	Start voltage	0 to 100	133
ADF	17	-	Reserved		
ADF	18	-	Reserved		
ADF	19	Sec	Start delay	0 to 10	120
ADF	20	-	Reserved		
ADF	21	-	Reserved		
ADF	22	Sec	DC braking time	0 to 60	126
ADF	23	Hz	DC brake cut-in frequency	0 to Max. output freq.	127
ADF	24	-	Reserved		
ADF	25	-	Reserved		
ADF	26	-	Reserved		
ADF	27	-	Reserved		
ADF	28	-	Reserved		
ADF	29	-	Reserved		
ADF	30	-	Reserved		
ADF	31	Hz	Output freq. low limit	0 to Max. freq.	201
ADF	32	Hz	Output freq. high limit	Min. freq. to Max. freq. range	202

## Appendix A

### Internal Floating Point (ADF) - Continued

NPT	NPA	UNIT	Description	Range	VLT 2800 PNU
ADF	33	Unit	Min reference	0 to Ref max.	204
ADF	34	Unit	Max. reference	Varies with Open or Closed Loop	205
ADF	35	Sec	Ramp Up Time 1	0.02 to 3600	207
ADF	36	Sec	Ramp Down Time 1	0.02 to 3600	208
ADF	37	Hz	Jog Frequency	0 to Max. output freq.	213
ADF	38	%	Preset Reference 1	-100 to +100	215
ADF	39	%	Preset Reference 2	-100 to +100	216
ADF	40	%	Preset Reference 3	-100 to +100	217
ADF	41	%	Preset Reference 4	-100 to +100	218
ADF	42	%	Current Limit	0 to Max. current	221

*Preset reference 1-4:* The drive will support four independent reference signals when programmed through digital input terminals 18, 19, 27, 29, or 33.

### Internal Integers (ADI)

NPT	NPA	UNIT	Description	Range	VLT 2800 PNU
ADI	1	-	Active setup	1 to 4	004

The point is global in all 4 setups



XREF BC  
NOT LOADED ON RIP

VLT® 2800

# Metasys N2 Instruction Manual



Danfoss can accept no responsibility for possible errors in catalogues, brochures and other printed material. Danfoss reserves the right to alter its products without notice. This applies to products already on order provided that such alterations can be made without subsequential changes being necessary in specifications already agreed.

