

■ Introduction	3
■ Quick Setup	4
■ The PROFIBUS interface	5
■ Eta-K - Physical connection	7
■ VLT 2800 - Physical connection	10
■ System layout	13
■ Timing	15
■ DP (Distributed Periphery)	16
■ Parameters	29
■ Warning and alarm messages	34
■ Glossary and parameter list	35
■ Index	38

Copyrights, Limitation of Liability and Revision Rights.

This publication contains information proprietary to Danfoss A/S. By accepting and using this manual the user agrees that the information contained herein will be used solely for operating equipment of Danfoss A/S or equipment from other vendors provided that such equipment is intended for communication with Danfoss equipment over a PROFIBUS serial communication link. This publication is protected under the Copyright laws of Denmark and most other countries.

Danfoss A/S does not warrant that a software program produced according to the guidelines provided in this manual will function properly in every physical, hardware or software environment.

Although Danfoss A/S has tested and reviewed the documentation within this manual, Danfoss A/S makes no warranty or representation, either express or implied, with respect to this documentation, including its quality, performance, or fitness for a particular purpose.

In no event shall Danfoss A/S be liable for direct, indirect, special, incidental, or consequential damages arising out of the use, or the inability to use information contained in this manual, even if advised of the possibility of such damages. In particular, Danfoss A/S is not responsible for any costs including but not limited to those incurred as a result of lost profits or revenue, loss or damage of equipment, loss of computer programs, loss of data, the costs to substitute these, or any claims by third parties.

Danfoss A/S reserves the right to revise this publication at any time and to make changes in its contents without prior notice or any obligation to notify previous users of such revisions or changes.

When reading through this manual, you will come across various symbols that require special attention.

The symbols used are the following:



Indicates a general warning.



Indicates something to be noted by the reader.



Indicates a high-voltage warning.

PROFIBUS is a registered trademark.

■ About this manual

This manual is intended to be used both as an instructional and as a reference manual. It only briefly touches on the basics of the PROFIBUS protocol whenever it is necessary for gaining an understanding of the PROFIDRIVE implementation of the PROFIBUS Profile for Variable Speed Drives (VDI/VDE 3689) and the DANFOSS PROFIBUS for the Eta-K and the VLT 2800.

The manual is also intended to serve as a guideline when you specify and optimize your communication system.

If you are not completely familiar with PROFIBUS or the Profile for Variable Speed Drives, it may be advisable to read some of the material provided on these subjects, eg DIN 19245 parts 1 and 3 and VDI/VDE 3689.

Even if you are an experienced PROFIBUS programmer, we suggest that you read this manual in its entirety before you start programming, since important information can be found in all chapters.

■ Assumptions

This manual assumes that you are using a Eta-K and a DANFOSS VLT 2800 with PROFIBUS. It is also assumed that you, as a master, are using a PLC or PC that is equipped with a serial communication card supporting all the PROFIBUS communication services required by your application, and that all requirements stipulated in the PROFIBUS standard as well as those set up in the PROFIBUS Variable Speed Drives Profile and its company-specific implementation PROFIDRIVE, as well as those pertaining to the VLT Variable Speed Drive are strictly observed as well as all limitations therein fully respected.

■ What you should already know

The DANFOSS PROFIBUS is designed to communicate with any master abiding by the PROFIBUS DP standard. It is therefore assumed that you have full knowledge of the PC or PLC you intend to use as a master in your system. Any questions pertaining to hardware or software produced by any other manufacturer is beyond the scope of this manual and is of no concern to DANFOSS.

If you have questions about how to set up master - master communication or communication to a non-Danfoss slave, the appropriate manuals should be consulted.

Programming: See the design guide:
Eta-K (MG.97.Gx.02)
VLT 2800 (MG.28.Ex.02)
for descriptions on how to programme the ordinary
Eta-K and VLT 2800.

Communication is established by setting the
parameters stated below.
Setting up the master: See the manual on the master
as well as the chapters of this manual giving details
on the PROFIBUS interface for information on how to
set up the master.

■ General information

Parameter 918:

Set the station address, - one unique address per
unit.

In parameters 502-508 it is possible to define how to
gate the control commands from the PROFIBUS with
the equivalent control commands of the digital inputs.

The Eta-K / VLT 2800 adjusts to the baudrate and
the configuration from the master.

■ **Master controlled Variable Speed Drives (VSD)**

The PROFIBUS Field-bus was designed to give you unprecedented flexibility and command over your VSD controlled system. The PROFIBUS will perform as an integrated part of your VLT VSD, giving you access to all parameters relevant to your application. The VSD will always act as a slave, and together with a master it can exchange a multitude of information and commands. Control signals such as *speed reference*, *start / stop* of motor, *reverse* operation, etc. are transmitted from the master in the form of a telegramme. The VSD acknowledges receipt by transmitting status signals, such as *running*, *on reference*, *motor stopped* and so on to the master. The VSD may also transmit fault indications, alarms and warnings to the master, such as *Overcurrent* or *Phase loss*.

The PROFIBUS communicates according to the *PROFIBUS Protocol Standard DIN 19245 parts 1 and 3*. This means that it can communicate with all masters that comply with this standard, but it does not necessarily mean that all services available in the PROFIBUS standard are supported. The *VDI / VDE 3689 PROFIBUS Profile for Variable Speed Drives* is a subset of PROFIBUS which only supports the services relevant to speed control applications. *PROFIDRIVE* is an implementation of VDI / VDE 3689 profile created by DANFOSS and a number of other companies.

Communication partners

In a control system the VSD will always act as a slave, and as such it may communicate with a single master or multiple masters depending on the nature of the application. A master may be a PLC or a PC that is equipped with a PROFIBUS communication card.

■ **Physical layer**

The field of application of a field-bus system is primarily determined by the transmission media and the physical bus interface selected. The type of bus cable required for the application and its installation (physical layer) are particularly important factors, in addition to the required transmission reliability of the physical level.

Though a fundamental feature of the PROFIBUS standard is the possibility of specifying several different physical interfaces, the standard, at the time of printing, has allowed for one universal specification only, namely the EIA Standard RS 485-A, which has found acceptance both in the field of factory automation and in several areas of the processing industry.

■ **Cable lengths/number of nodes**

The maximum cable length in one segment is depending on the transmission speed. The total cable length includes drop cables if any. A drop cable is the connection from the main bus cable to each node if a T-connection is used instead of connecting the main bus cable directly to the nodes, see drop cable length. The table below shows the maximum allowed cable length and maximum number of nodes/VLT's with 1, 2, 3 and 4 bus segments.

Note that a repeater is a node in both of the two segments it connects. The number of VLT is based on a single master system. If there are more masters the number of VLT must be reduced correspondingly.

Max. total bus cable length

	1 segment: 32 nodes (31 VLT)	2 segments: 64 nodes (1 repeater, 61 VLT)	3 segments: 96 nodes (2 repeaters, 91 VLT)	4 segments: 128 nodes (3 repeaters, 121 VLT)
Transmission speed	[m]	[m]	[m]	[m]
9.6-187.5 kBaud	1000	2000	3000	4000
500 kBaud	400	800	1200	1600
1.5 MBaud	200	400	600	800
3 MBaud	100	200	300	400

The total drop cable length for one segment is limited as stated in the table below.

Drop cable length	Max. drop cable length per segment
Transmission speed	[m]
9.6-93.75 kBaud	96
187.5 kBaud	75
500 kBaud	30
1.5 MBaud	10
3 MBaud	none

- Damping: max. 9 dB over the whole wire length
- Cross section: max. 0.34 mm², corresponding to AWG 22
- Cable type: twisted in pairs, 1 x 2, or 2 x 2, or 1 x 4 wires
- Screening: Copper-braided screen or braided screen and foil screen

It is recommended to use the same cable type in the entire network to avoid impedance mismatch.

The length statements in the tables above are valid provided that bus cable with the following properties is used:

- Impedance: 135 to 165 ohm at a measuring frequency from 3 to 20 MHz
- Resistance: < 110 ohm/km
- Capacity: < 30 pF/m

The numbers on the following drawing indicate the maximum number of stations in each segment. They are not the station addresses as each station in the network must have a unique address.

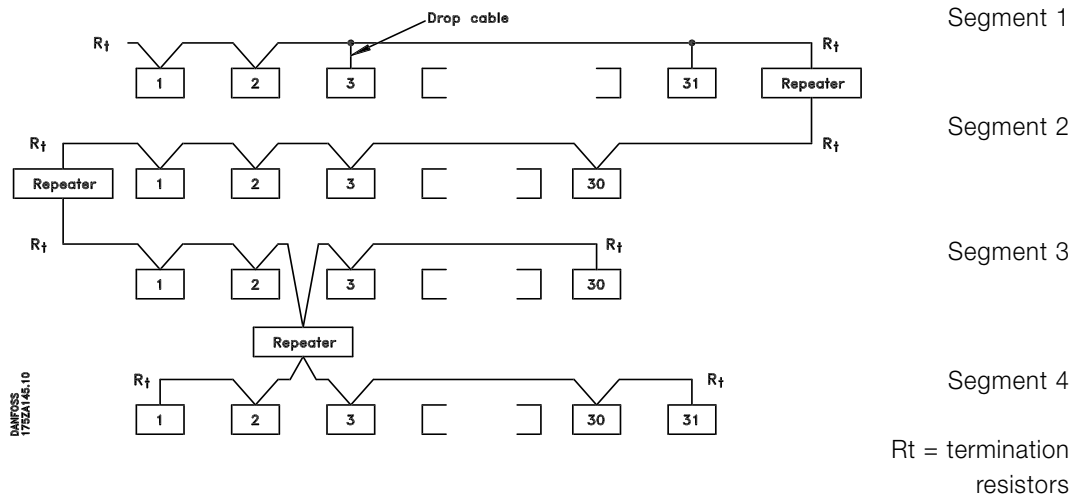

Eta-K:

Physical connection

The PROFIBUS is connected to the bus line via X100, terminals 1 and 2.

It is recommended to use a master with a galvanic isolated bus driver and with over voltage protection (e.g. zenerdiode).

EMC precautions

The following EMC precautions are recommended to obtain interference free operation of the PROFIBUS network. Additional information on EMC can be found in the design guide on the Eta-K (MG.97.Gx.02). Please also consult the manual of the PROFIBUS master for further installation guidelines.



Relevant national and local regulations, for example regarding protective earth connection, must be observed.

- Cable routing
The PROFIBUS communication cable must be kept away from motor and brake resistor cables to avoid coupling of high frequency noise from one cable to the other. Normally a distance of 200 mm is sufficient, but it is generally recommended to keep the greatest possible distance between the cables, especially where cables are running in parallel over long distances.

If the PROFIBUS cable has to cross a motor and brake resistor cable they must cross each other at an angle of 90°.

- Connection of the cable screen
The screen of the PROFIBUS cable must always be connected to ground at both ends, that means the screen must be connected to ground in all stations connected to the PROFIBUS network. It is very important to have a low impedance ground connection of the screen, also at high frequencies. This can be obtained by connecting the surface of the screen to ground, for example by means of a cable clamp or a conductive cable gland.

- Earth connection
It is important that all stations connected to the PROFIBUS network are connected to the same earth potential. The earth connection must have a low HF (high frequency) impedance. This can be achieved by connecting a large surface area of the cabinet to earth, for example by mounting the Eta-K on a conductive rear plate.

Especially when having long distances between the stations in a PROFIBUS network it can be necessary to use additional potential equalizing cables, connecting the individual stations to the same earth potential.

The Eta-K is provided with different clamps and brackets to enable a proper ground connection of the PROFIBUS cable screen. The screen connection is shown in the following drawing.

Connecting the bus line

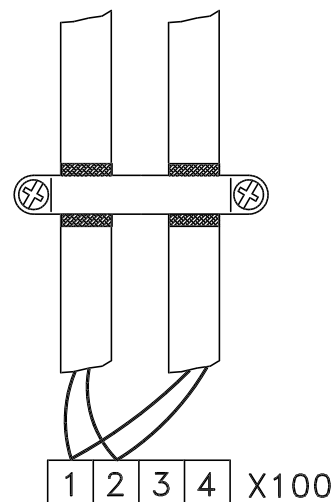

DANFOSS
175ZA307.10

Eta-K:

The bus termination

See drawing on page 6

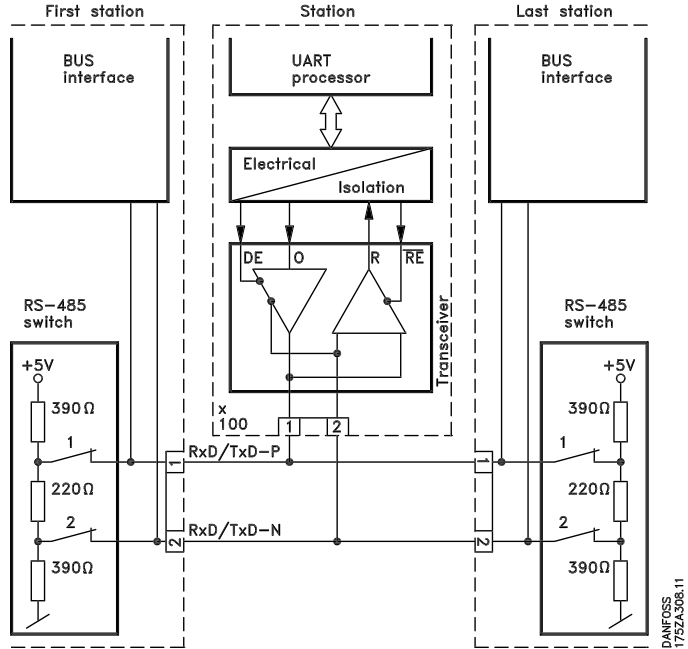

It is essential that the bus line be terminated properly. A mismatch of impedance may result in reflections on the line that will corrupt data transmission.



The switches should *never* be left in opposite positions. They should either both be ON or both be OFF!

- The PROFIBUS is provided with a suitable termination which may be activated by the switches of the RS485 switch block located just to the left of the terminal block X100 (see drawing below). The switches should be on to terminate the bus.

- Most masters and repeaters are equipped with their own termination.
- If an external termination circuit consisting of three resistors is connected to the bus line a 5 V d.c. power supply must be used, please note that this must be galvanically isolated from the a.c. line.

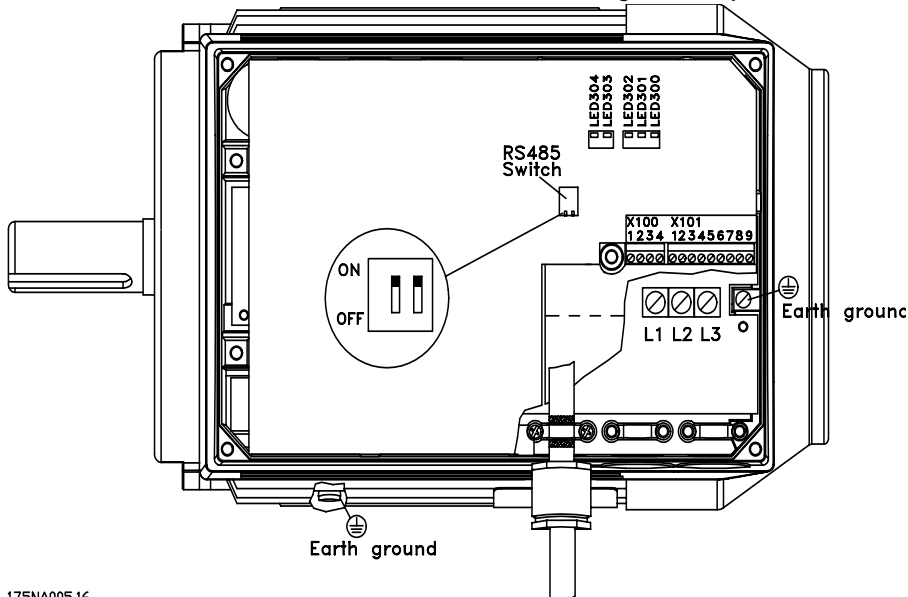

175NA005.16

Eta-K:

■ LEDs

There are 2 LEDs on the PROFIBUS:

LED303: Lights up when the card is initialized and ready to communicate. It will flash while auto baudrate detection is attempting to detect the actual baudrate.

LED304: Lights up when the card is communicating, depending on baudrate.



A high baudrate results in dim light in LED304.

VLT 2800:

■ **Physical connection**

The PROFIBUS is connected to the bus line via, terminals 68 and 69.

It is recommended to use a master with a galvanic isolated bus driver and with over voltage protection (e.g. zenerdiode).

EMC precautions

The following EMC precautions are recommended to obtain interference free operation of the PROFIBUS network. Additional information on EMC can be found in the design guide on the VLT 2800 (MG.28.Ex.02). Please also consult the manual of the PROFIBUS master for further installation guidelines.



Relevant national and local regulations, for example regarding protective earth connection, must be observed.

- Cable routing

The PROFIBUS communication cable must be kept away from motor and brake resistor cables to avoid coupling of high frequency noise from one cable to the other. Normally a distance of 200 mm is sufficient, but it is generally recommended to keep the greatest possible distance between the cables, especially where cables are running in parallel over long distances.

If the PROFIBUS cable has to cross a motor and brake resistor cable they must cross each other at an angle of 90°.

- Connection of the cable screen

The screen of the PROFIBUS cable must always be connected to ground at both ends, that means the screen must be connected to ground in all stations connected to the PROFIBUS network. It is very important to have a low impedance ground connection of the screen, also at high frequencies. This can be obtained by connecting the surface of the screen to ground, for example by means of a cable clamp or a conductive cable gland.

The VLT 2800 Series is provided with different clamps and brackets to enable a proper ground connection of the PROFIBUS cable screen. The screen connection is shown in the following drawing.

- Earth connection

It is important that all stations connected to the PROFIBUS network are connected to the same earth potential. The earth connection must have a low HF (high frequency) impedance. This can be achieved by connecting a large surface area of the cabinet to earth, for example by mounting the VLT 2800 on a conductive rear plate.

Especially when having long distances between the stations in a PROFIBUS network it can be necessary to use additional potential equalizing cables, connecting the individual stations to the same earth potential.

Connecting the bus line

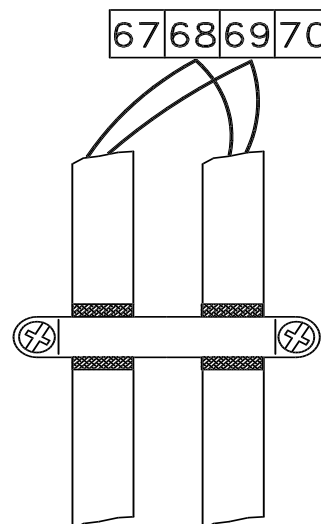

195NA102.12

VLT 2800:

The bus termination

See drawing on page 6

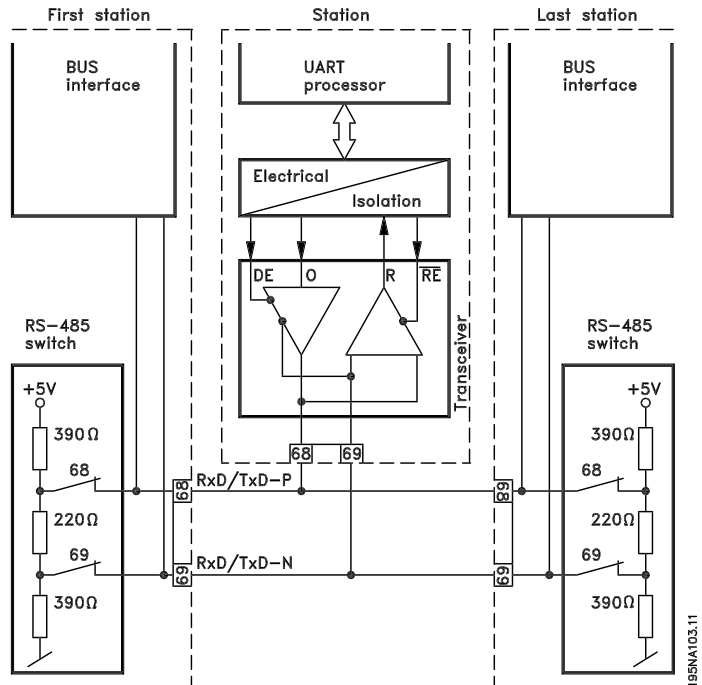

It is essential that the bus line be terminated properly. A mismatch of impedance may result in reflections on the line that will corrupt data transmission.

- The PROFIBUS is provided with a suitable termination which may be activated by the switches of the RS485 switch block located just to the left of the terminal block X100 (see drawing below). The switches should be on to terminate the bus.

- Most masters and repeaters are equipped with their own termination.

- If an external termination circuit consisting of three resistors is connected to the bus line a 5 V d.c. power supply must be used, please note that this must be galvanically isolated from the a.c. line.

 The switches should *never* be left in opposite positions. They should either both be ON or both be OFF!

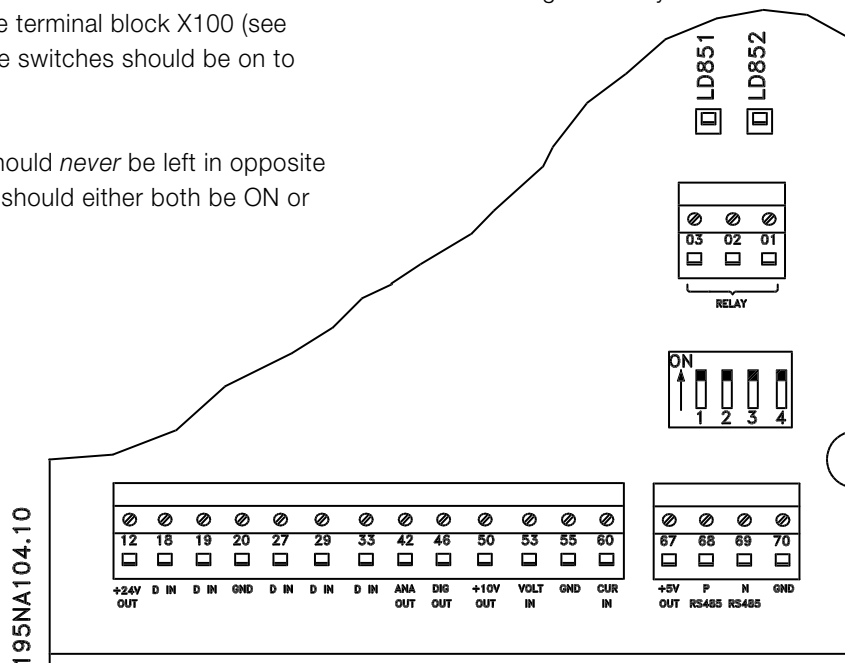

VLT 2800:

■ LEDs

There are 2 LEDs on the PROFIBUS:

LD851: Lights up when the card is initialized and ready to communicate. It will flash while auto baudrate detection is attempting to detect the actual baudrate.

LD852: Lights up when the card is communicating, depending on baudrate.



A high baudrate results in dim light in LD852.

■ **Bus topology**

Single master operation with DP

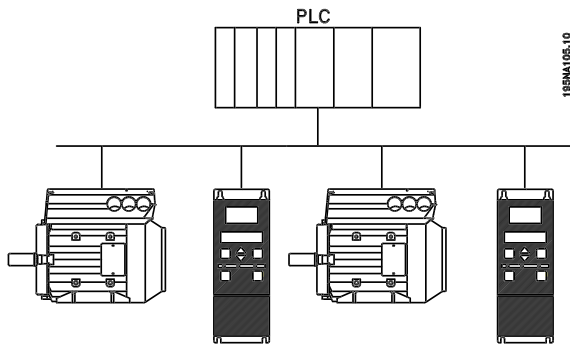

- Single master
- PLC communicates with telegrams of constant length
- Fits to time critical requirements
- No need for equidistant transmissions of set points

Cyclical transmission

1. Set point transmission
2. Actual value feed back
3. New setpoints computed
4. New setpoint transfer

Features of DP (Distributed Periphery)

- Is used by several PLC manufacturers for remote peripheral I/O communication.
- Supports cyclical communication.
- SRD service gives fast cyclical exchange of process data between master and slaves.
- Freeze and synchronize function is supported
- Fixed data structure.
- Fixed telegramme size.
- Occupies I/O memory space in PLC proportional to the number of slaves employed, which may limit the number of participants. Additional data require additional I/O memory space.

DP should be used when fast cyclical process control is needed. Such a concept would typically call for single master operation with a limited number of slave stations. (A high number of slaves will reduce the system response).

This could also be the case where control loops are closed over the bus.

As a very fast alternative it is of course possible to close the control loop outside the bus.

Transferring large amount of data where rapid transfer of process data does not have highest priority

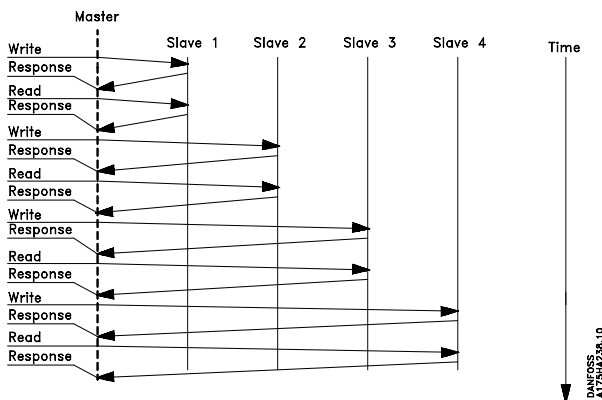

Closing the control loop over the bus

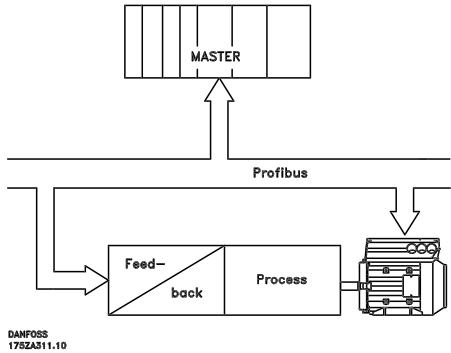

Closing the control loop outside the fieldbus for extremely fast feed-back

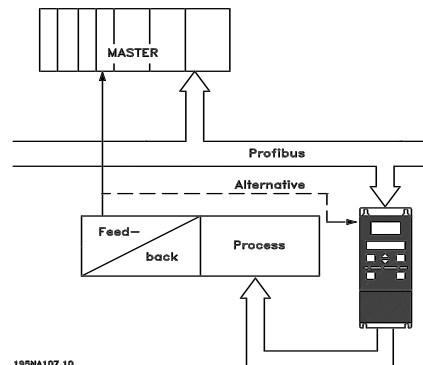
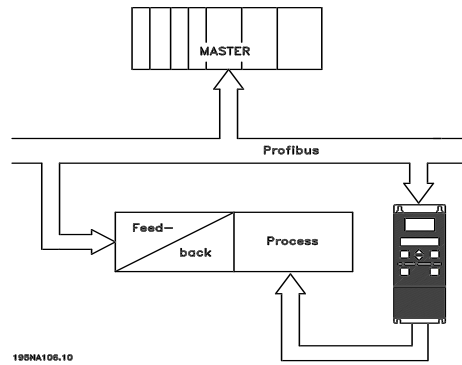
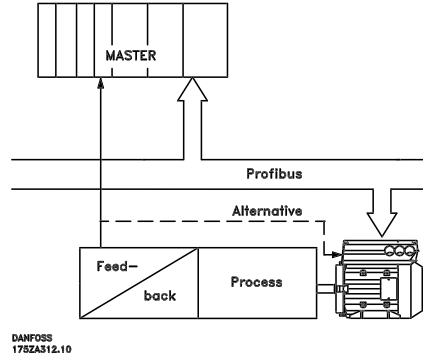

Rapid Cyclical transmission with PPO using DP

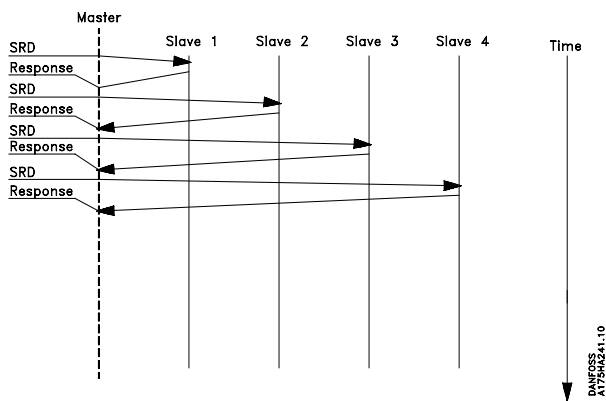

Parameter up-/downloads can be achieved by using the so-called Parameter / Process Objects - PPOs - of 12, 20 or 28 bytes length as specified in the VDI/ VDE 3689 profile, see drawing page 16.

This procedure, however, occupies 8 bytes additional I/O memory space in the PLC bytes per slave, and slows down the system (see also "Timing" page 15).

Control of the drives during normal operation is often very time critical, but it involves very few data, such as control commands and speed reference. DP is optimized for fast cyclical communication.

■ Features and services supported by Eta-K and the VLT 2800

Features available as described by the unit classification

The unit classification as layed out in the PROFIBUS Profile for VSDs describes the functionality of the unit. There are 4 classes where class 1 signifies the lowest performance class, and class 4 the highest.

The Eta-K / VLT 2800 is a class 3 unit except for the following features:

- Fault buffer
- Change access rights for parameter *write*
- Change access rights for *process control*
- Time difference
- Hardware configuration ident.

The Eta-K / VLT 2800 complies with the following class 4 features:

- Baudrate > 500 kBaud
- Programmable content of PCD 3 through 6 (10) of the PPO's
- PPO type 5

■ **Eta-K / VLT 2800 response time**

The update time via the PROFIBUS connection can be divided in two parts:

1) The communication time, which is the time it takes to transmit data from the master to the slave (Eta-K / VLT 2800 with PROFIBUS), and 2) the internal update time, which is the time it takes to transmit data between the Eta-K / VLT 2800 control card and the PROFIBUS.

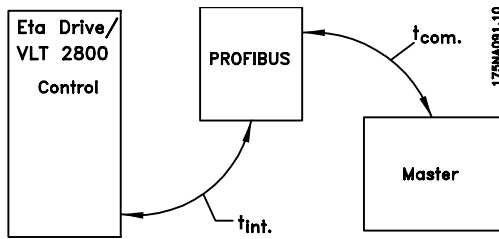

Communication time (t_{com}) depends on the actual transmission speed (baudrate) and the type of master in use. The minimum obtainable communication time with the Eta-K / VLT 2800 with PROFIBUS is approx. 100 μ sec per slave, when using DP communication with 4 bytes of data (PPO type 3) at 3 Mbaud. More data or lower transmission speed will increase the communication time.

The internal update time (t_{int}) depends on the type of data in question as there are different channels for the data transfer where time critical data e.g. control word has highest priority. The internal update time for the different types of data are stated below.

Data	Update time, t_{int}
Control word/Main reference (part of PPO)	42 msec
Status word/Actual output frequency (part of PPO)	40 msec
Parameter read (PCD 1-8)	40 msec
Parameter write (PCD 1-2)	160 msec
Parameter write (PCD 3-4)	320 msec
Parameter write (PCD 5-8)	640 msec
Parameter read (PCV)	41 msec
Parameter write (PCV)	40 msec

■ **System update time**

The system update time is the time it takes to update all the slaves in the network when using cyclical communication. The drawing below shows the value which is obtainable in theory at 2 input and 2 output bytes.

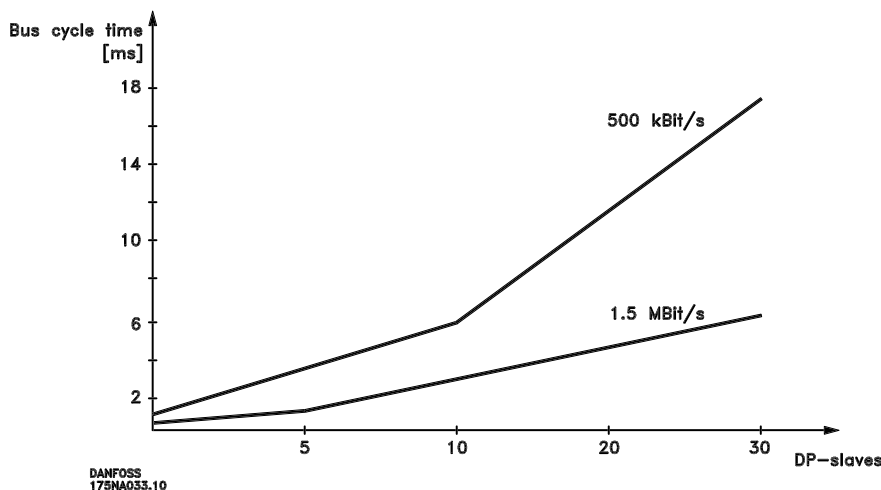

DP

DP communication relations

Communication according to PROFIBUS DP, i.e. DIN 19245 part 1 & 3, is supported. Consequently a master that supports PROFIBUS DP must be used.

By DP communication one of the parameter-process data objects (PPO's) described below must be used.

PPO description

A special feature of the PROFIBUS Profile for VSD's is the communication object called a PPO, meaning *Parameter-Process Data Object*.

The PPO is well suited for fast cyclical data transfer, and may, as the name implies, carry both process data and parameters.

The selection of PPO type is made according to the master request.

A PPO may consist of a parameter part and process data part. The parameter part can be used for reading and/or updating the parameters one by one.

The process data part consists of a fixed part (4 bytes) and a parametrable part (8 or 16 bytes). In the fixed part control word and speed reference are transferred to the VLT while status word and actual output frequency feedback are transferred from the VLT. In the parametrable part the user chooses which parameters have to be transferred to (parameter 915) and which from (parameter 916) the VLT.

Type 1, 2 and 5 consist of the parameter part and 4, 12 and 20 byte process data, respectively.

Type 3 and 4 consist of 4 and 12 byte process data, respectively.

PPO. Parameter-Process Data Object

By DP one of the following shown PPO's must be used:

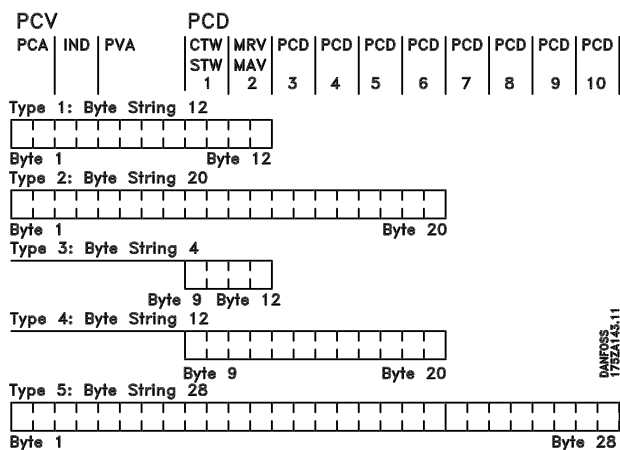

- PCD: Process Data
 - PCV: Parameter-Characteristics-Value
 - PCA: Parameter-Characteristics (Bytes 1, 2)
PCA handling below
 - IND: Subindex (Byte 3), (Byte 4 is not used)
 - PVA: Parameter value (Bytes 5 to 8)
 - CTW: Control word
 - STW: Status word
 - MRV: Main reference value
 - MAV: Main actual value (Actual output frequency)
- } see page 22

■ **PCA handling**

The PCA portion of the PPO types 1, 2 and 5 will handle a number of tasks. The master may control and supervise parameters and request a response from the slave, while the slave, apart from responding to a request from the master may transmit a spontaneous message.

Requests and responses is a handshake procedure and cannot be batched, meaning that if the master sends out a *Read/write* request, it has to wait for the response, before it sends a new request. The request or response data value will be limited to max. 4 bytes, which implies that text strings are not transferable.

PCA - Parameter Characteristics

15	14	13	12	11	10	9	8	7	6	5	4	3	2	1	0
RC				SMP	PNU										

RC: Request/respons Characteristics (Range: 0..15)

SPM: Toggle-Bit for Spontaneous Messages

PNU: Parameter # (Range: 1..1999)

Request/response handling

The RC portion of the PCA word defines the requests that may be issued from the master to the slave as well as what other portions of the PCV (IND and PVA) are involved.

The PVA portion will transmit word-size parameter values in bytes 7 and 8, while long word size values require bytes 5 to 8 (32 bits).

If the Response / Request contains array elements, the IND will carry the Array Subindex. If parameter descriptions are involved, the IND will hold the Record Subindex of the Parameter description.

RC content

Request	Function
0	No request
1	Request parameter value
2	Change parameter value (word)
3	Change parameter value (long word)
4	Request description element
5	Change description element
6	Request parameter value (array)
7	Change parameter value (array word)
8	Change parameter value (array long word)
9	Request number of array elements
10-15	Not used

Response	Function
0	No response
1	Transfer parameter value (word)
2	Transfer parameter value (long word)
3	Transfer description element
4	Transfer parameter value (array word)
5	Transfer parameter value (array long word)
6	Transfer number of array elements
7	Request rejected (incl. fault #, see below)
8	Not seviceable by PCV interface
9	Spontaneous message (word)
10	Spontaneous message (long word)
11	Spontaneous message (array word)
12	Spontaneous message (array long word)
13-15	Not used

If the slave rejects a request from the master, the RC word in the PPO-read will indicate this by assuming the value 7. The fault # will be carried by bytes 7 and 8 in the PVA element.

Fault #	Interpretation
0	Illegal PNU
1	Parameter value cannot be changed
2	Upper or lower limit exceeded
3	Subindex corrupted
4	No array
5	Data type false
6	Cannot be set by user (reset only)
7	Description element cannot be changed
8	IR required PPO-write not available
9	Description data not available
10	Access group
11	No parameter write access
12	Key word missing
13	Text in cyclical transmission not readable
14	Name in cyclical transmission not readable
15	Text array not available
16	PPO-write missing
17	Request temporarily rejected
18	Other fault
19	Date in cyclical transmission not readable
130	There is no bus access to the parameter called
131	Data change is not possible because factory Setup has been selected

DP

■ **Parameter and data type structure description**

Parameter description:

DP has a number of describing attributes (see right).

Read/write on parameter description is made by the PCV part using the RC commands 4/5 and subindex of the desired description element.

Size attribute

The *size index* and the *conversion index* for each parameter can be taken from the parameter list on page 37.

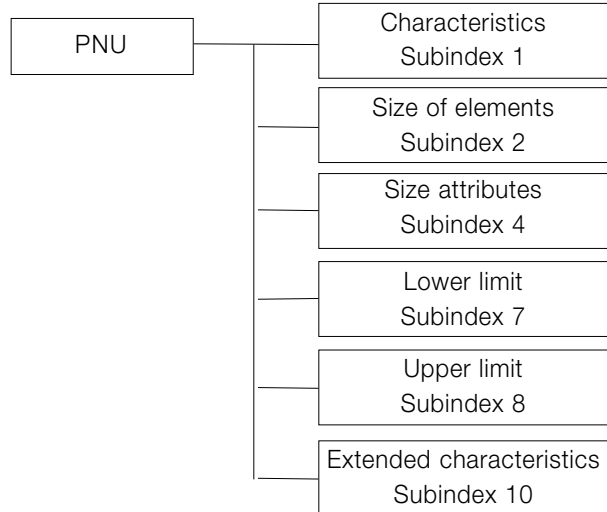

Physical unit	Size index	Measuring unit	Designation	Conversion index	Conversion factor
	0	No dimension		0	1
		second	s	0	1
				-1	0.1
				-2	0.01
Time	4	millisecond	ms	-3	0.001
		minute	min	70	60
		hour	h	74	3600
		day	d	77	86400
Energy	8	watthour	Wh	0	1
		kilowatthour	kWh	3	1000
		megawatthour	MWh	6	10 ⁶
Power	9	milliwatt	mW	-3	0.001
		watt	W	0	1
		kilowatt	kW	3	1000
		megawatt	MW	6	10 ⁶
Rotation	11	rotation per minute	RPM	0	1
Torque	16	newtonmeter	Nm	0	1
		kilonewtonmeter	kNm	3	1000
Temperature	17	degree Celsius	°C	0	1
Voltage	21	millivolt	mV	-3	0.001
		volt	V	0	1
		kilovolt	kV	3	1000
Current	22	milliampere	mA	-3	0.001
		ampere	A	0	1
		kiloampere	kA	3	1000
Resistance	23	milliohm	mOhm	-3	0.001
		ohm	Ohm	0	1
		kiloohm	kOhm	3	1000
Ratio	24	per cent	%	0	1
Relative change	27	per cent	%	0	1
Frequency	28	hertz	Hz	0	1
		kilohertz	kHz	3	1000
		megahertz	MHz	6	10 ⁶
		gigahertz	GHz	9	10 ⁹

■ **Object and data types supported by Eta-K and VLT 2800**

Data types supported by Eta-K and VLT 2800

Data type	Object Code	Short name	Description
3	5	12	Integer 16
5	5		Unsigned 8
6	5	O2	Unsigned 16
7	5	O4	Unsigned 32
10	5		Byte string
13	5		Time difference ¹⁾
33	5	N2	Standardized value (16 bit) ¹⁾
35	5	V2	Bit sequence ¹⁾

¹⁾ See elaboration below

Time difference

The data type time difference is a time indication in milliseconds.

Notation: Time difference

Value range: $0 \leq i \leq (2^{32} - 1)$ milliseconds

Coding: The time is presented as a binary value of 32 bits (4 bytes). The first four (MSB) bits are always zero. Time difference is thus a byte string of 4 bytes.

Data coding of the data type time difference

Bit	Byte 1	Byte 2	Byte 3	Byte 4	
8	0 ms	2^{23} ms	2^{15} ms	2^7 ms	MSB
7	0 ms	2^{22} ms	2^{14} ms	2^6 ms	MSB
6	0 ms	2^{21} ms	2^{13} ms	2^5 ms	MSB
5	0 ms	2^{20} ms	2^{12} ms	2^4 ms	MSB
4	2^{27} ms	2^{19} ms	2^{11} ms	2^3 ms	
3	2^{26} ms	2^{18} ms	2^{10} ms	2^2 ms	
2	2^{25} ms	2^{17} ms	2^9 ms	2^1 ms	
1	2^{24} ms	2^{16} ms	2^8 ms	2^0 ms	

Standardized value

A binary value.

0% = 0 (0h), 100% is 2^{14} (4000h)

Data type	N 2
Range	-200% ... 200% – 2^{-14}
Resolution	$2^{-14} = 0.0061\%$
Length	2 bytes

Notation: 2's complement notation.
MSB is 1st bit after sign bit in 1st byte.
Sign bit = 0 = positive number
Sign bit = 1 = negative number

Bit	8	7	6	5	4	3	2	1
Byte 1	SIGN	2^0	2^{-1}	2^{-2}	2^{-3}	2^{-4}	2^{-5}	2^{-6}
Byte 2	2^{-7}	2^{-8}	2^{-9}	2^{-10}	2^{-11}	2^{-12}	2^{-13}	2^{-14}

Bit sequence

16 boolean values for control and presentation of user functions. Notation is binary.

Bit	8	7	6	5	4	3	2	1
Byte 1	15	14	13	12	11	10	9	8
Byte 2	7	6	5	4	3	2	1	0

■ **Spontaneous messages**

The Spontaneous message is activated by the active parameters i.e. 538, 540, or 953 and will be carried with the PCV response, stating PNU and PVA of the changed active parameter that triggered the message.

Spontaneous messages are generated when the value is changed in one of the abovementioned parameters. It means that a message will be sent when a warning comes, and when a warning disappears.

Simultaneously the VLT will toggle the SPM bit (11) of PCA word (see "PCA handling" page 17).

The Spontaneous messages will be transmitted until the master has acknowledged reception of the message by changing the SPM bit.



Spontaneous messages are only active when parameter 917 is "ON"!

Example of SPM execution

In the VLT the SPMs are temporarily stored in a FIFO buffer. This means that up to 16 consecutive SPMs can be retained. If only one SPM has entered the FIFO, the VLT will resume normal communication as soon as the SPM has been acknowledged by the master (and the condition causing the SPM been rectified). If more SPMs are in the FIFO, these will be transmitted consecutively upon acknowledgement. If more SPMs are triggered when the FIFO is full, these will be ignored.

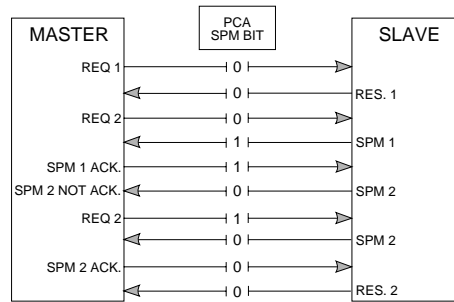

■ Synchronize and freeze

The control commands SYNC/UNSYNC and FREEZE/UNFREEZE are broadcast functions. SYNC/UNSYNC is used to send synchronized control commands and/or speed reference to all the connected slaves (Eta-K / VLT 2800 Series). FREEZE/UNFREEZE is used to freeze the status feedback in the slaves to get synchronized feedback from all connected slaves.

The synchronize and freeze commands only affect Process Data (the PCD part of the PPO).

SYNC/UNSYNC

SYNC/UNSYNC can be used to obtain simultaneous reactions in several slaves, for example synchronised start, stop or speed change. A SYNC command will freeze the actual control word and speed reference, incoming Process Data will be stored but not used until a new SYNC command or a UNSYNC command is received.

See the example below where the left column holds the speed reference send out by the master and the three right columns hold the actual speed reference used in each of the three slaves.

	Actual slave speed reference		
	VLT Address 3	VLT Address 4	VLT Address 5
From DP master to address:			
1. Speed reference = 50 % to address 3	⇒ 50 %	0 %	0 %
2. Speed reference = 50 % to address 4	50 %	⇒ 50 %	0 %
3. Speed reference = 50 % to address 5	50 %	50 %	⇒ 50 %
4. SYNC command to all addresses	⇒ 50 %	⇒ 50 %	⇒ 50 %
5. Speed reference = 75 % to address 3	⇒ 50 %	50 %	50 %
6. Speed reference = 75 % to address 4	50 %	⇒ 50 %	50 %
7. Speed reference = 75 % to address 5	50 %	50 %	⇒ 50 %
8. SYNC command to all addresses	⇒ 75 %	⇒ 75 %	⇒ 75 %
9. Speed reference = 100 % to address 3	⇒ 75 %	75 %	75 %
10. Speed reference = 50 % to address 4	75 %	⇒ 75 %	75 %
11. Speed reference = 25 % to address 5	75 %	75 %	⇒ 75 %
12. UNSYNC command to all addresses	⇒ 100 %	⇒ 50 %	⇒ 25 %
13. Speed reference = 0 % to address 3	⇒ 0 %	50 %	25 %
14. Speed reference = 0 % to address 4	0 %	⇒ 0 %	25 %
15. Speed reference = 0 % to address 5	0 %	0 %	⇒ 0 %

FREEZE/UNFREEZE

FREEZE/UNFREEZE can be used to get simultaneous reading of Process Data for example output current from several slaves. A FREEZE command will freeze the current actual values and on request the slave will send back the value that was present when the FREEZE command was received. The actual values will be updated when a new FREEZE or UNFREEZE command is received.

See the example below where the left column holds the current values read by the master and the three right columns hold the actual output current of the three slaves.

	Actual slave output current		
	VLT	VLT	VLT
DP master reads address:	Address 3	Address 4	Address 5
1. Address 3 output current = 2 A	← 2 A	3 A	4 A
2. Address 4 output current = 5 A	2 A	← 5 A	2 A
3. Address 5 output current = 3 A	3 A	2 A	← 3 A
4. FREEZE command to all addresses	⇒ 1 A	⇒ 3 A	⇒ 3 A
5. Address 3 output current = 1 A	← 4 A	2 A	5 A
6. Address 4 output current = 3 A	2 A	← 2 A	2 A
7. Address 5 output current = 3 A	3 A	1 A	← 2 A
8. UNFREEZE command to all adresses	⇒ 2 A	⇒ 3 A	⇒ 4 A

Reading as by 1, 2 and 3

DP
■ Control word / status word

The bits of the “Control word” tell the VLT how to react, while the “Status word” bit status will tell the master the condition of the VLT.

Control word

The control words are used to send control commands to the frequency converter when the telegram is sent from the master.

Control word				
According to PROFIDRIVE control word (para. 512=0)			According to VLT standard (para. 512=1)	
Bit	Bit = 0	Bit = 1	Bit = 0	Bit = 1
00 (LSB)	OFF 1	ON 1	Preset reference	
01	OFF 2	ON 2		
02	OFF 3	ON 3	DC brake	Ramp
03	Motor coasting	Enable	Coasting	Enable
04	Quick-stop	Ramp	Quick-stop	Ramp
05	Freeze output frequency	Ramp enable	Freeze output	Ramp enable
06	Ramp stop	Start	Ramp stop	Start
07	No function	Reset	No function	Reset
08	Jog 1 OFF	ON	No function	Jog
09	Jog 2 OFF	ON		
10	Data not valid	Valid	Data not valid	Valid
11	No function	Slow down	No function	
12	No function	Catch-up	No function	
13	Setup select		Setup select	
14				
15 (MSB)	No function	Reversing	No function	Reversing

The Eta-K Design Guide (MG.97.GX.02) and the VLT 2800 Series Design Guide (MG.28.EX.02) holds a detailed description of the control word.

Status word

When the frequency converter returns the frame to the master, the same two bytes operate as status from the frequency converter with the following functions:

Status word				
According to PROFIDRIVE control word (para. 512=0)			According to VLT standard (para. 512=1)	
Bit	Bit = 0	Bit = 1	Bit = 0	Bit = 1
00 (LSB)	Control not ready	Ready		
01	VLT not ready	Ready	VLT not ready	Ready
02	Motor coasting	Enable	Coasting	Enable
03	No fault	Trip	No fault	Trip
04	ON 2	OFF 2	R e s e r v e d	
05	ON 3	OFF 3	R e s e r v e d	
06	Start enable	Start disable	R e s e r v e d	
07	No warning	Warning	No warning	Warning
08	Speed ≠ ref.	Speed = ref.	Speed ≠ ref.	Speed = ref.
09				
10	Out of range	Frequency OK	Out of range	Frequency OK
11	Not running	Running	Not running	Running
12				
13	Voltage OK	Limit	Voltage OK	Above limit
14	Torque OK	Limit	Current OK	Above limit
15 (MSB)	No thermal warning	Thermal warning	No thermal warning	Thermal warning

The Eta-K Design Guide (MG.97.GX.02) and the VLT 2800 Series Design Guide (MG.28.EX.02) holds a detailed description of the status word.

■ Example

This example shows how PPO type 1 is used for changing the ramp-up time (parameter 207) to 10 seconds and for commanding a start and speed reference of 50%.

PPO. Parameter-Process Data Object

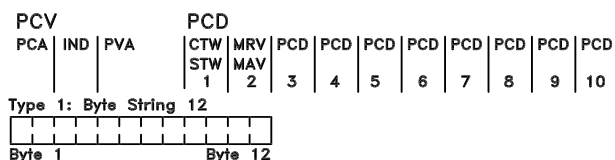

- | | |
|---|-------------------------------------|
| PCD: Process Data | PVA: Parameter value (Bytes 5 to 8) |
| PCV: Parameter-Characteristics-Value | CTW: Control word } see page 22 |
| PCA: Parameter-Characteristics (Bytes 1, 2)
PCA handling below | STW: Status word } |
| IND: Subindex (Byte 3), (Byte 4 is not used) | MRV: Main reference value |
| | MAV: Main actual value |

PCV

PCA - Parameter Characteristics

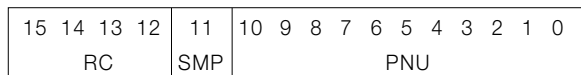

- RC: Request/respons Characteristics (Range: 0..15)
 SMP: Toggle-Bit for Spontaneous Messages
 PNU: Parameter # (Range: 1..1999)

PCA part (byte 1-2)

The RC part tells what the PCV part must be used for. The functions available appear from the table, page 17.

When a parameter is to be changed, choose value 2 or 3, in this example 3 is chosen, because parameter 207 covers a long word (32 bits).

SPM bit:

The function is explained on page 19, in the example the function *Spontaneous Messages* is not applied (parameter 917 = OFF), therefore SPM is set for 0. PNU = Parameter number: Parameter number is set for: 207 = CF Hex. This means that the value of the PCA part is 30CF Hex.

IND (bytes 3-4):

Used when reading/changing parameters with subindex, for example parameter 915. In the example bytes 3 and 4 are set for 00 Hex.

PVA (bytes 5-8):

The data value of parameter 207 must be changed to 10.00 seconds. The value transmitted must be 1000, because the conversion index for parameter 207 is -2, this means that the value received by VLT is divided by 100, making VLT *perceive* 1000 as 10.00. Bytes 5-8 = 1000 = 03E8 Hex.

PCD

CTW according to Profidrive profile:

Control words consisting of 16 bits, the meaning of the various bits appears from the table, page 22.

The following bit pattern sets all necessary start commands: 0000 0100 0111 1111 = 047F Hex.*

0000 0100 0111 1110 = 047E Hex.*

0000 0100 0111 1111 = 047F Hex.

Quickstop: 0000 0100 0110 1111 = 046F Hex.

Stop: 0000 0100 0011 1111 = 043F Hex.

* Only necessary at power up.

MRV:

Speed reference, the data format is "Standardized value", see page 19. 0 Hex = 0% and 4000 Hex = 100%.

In the example 2000 Hex is used corresponding to 50% of maximum frequency (parameter 202).

The whole PPO therefore gets the following value in Hex:

	Byte	Value
	PCA	1
	PCA	2
	IND	3
PCV	IND	4
	PVA	5
	PVA	6
	PVA	7
	PVA	8
PCD	CTW	9
	CTW	10
	MRV	11
	MRV	12

The Process data within the PCD part is acting on the VLT immediately, and can be updated from the master as quickly as possible.

The PCV part is a "hand shake" procedure which means that the VLT has to acknowledge the command, before a new one can be written.

- A positive response of the above example may look like this:

	Byte	Value
	PCA	1
	PCA	2
	IND	3
PCV	IND	4
	PVA	5
	PVA	6
	PVA	7
	PVA	8
PCD	STW	9
	STW	10
	MAV	11
	MAV	12

The PCD part responds according to the state and parametrization of the VLT.

The PCV part responds as:

PCA: As the request telegram, but here the RC part is taken from the response table on page 16. In this example RC is 2Hex, which is a confirmation that a parameter value of the type long word (32 bit) has been transferred.

IND is not used in this example.

PVA: 03E8Hex in the PVA part tells that the value of the parameter in question (207) is 1000 which corresponds to 10.00.

STW: 0F07 Hex means that the motor is running and there are no warnings or faults (for details see Status word table on page 22).

MAV: 2000 Hex tells that the output frequency is 50% of max. frequency.

- A negative response may look like this:

	Byte	Value	
PCV	PCA	1	70
	PCA	2	00
	IND	3	00
	IND	4	00
	PVA	5	00
	PVA	6	00
	PVA	7	00
	PVA	8	02
PCD	STW	9	0F
	STW	10	07
	MAV	11	20
	MAV	12	00

RC is 7 Hex which means that the request has been rejected, and the fault number can be found in the PVA part. In this case the fault number is 2 which means that the upper or lower limit of the parameter is exceeded. See fault number table on page 17.

Eta-K:

■ GSD-file

The GSD-file is a DP “standard” text file containing the necessary data for configuring DP slaves within a standard DP master.

```

GSD-file: DA010403.GSD
GSD-file for Eta-K Series with PROFIBUS

#Profibus_DP
Vendor_Name = "Bauer";
Model_name = "Eta-K serie K";
Revision = "00";
Ident_Number = 0x0403;
Protocol_Ident = 0;
Station_type = 0;
FMS_supp = 0;
Hardware_Release = "2.0";
Software_Release = "1.10";
9.6_supp = 1;
19.2_supp = 1;
93.75_supp = 1;
187.5_supp = 1;
500_supp = 1;
1.5M_supp = 1;
3M_supp = 1;
6M_supp = 0;
12M_supp = 0;
MaxTsd_9.6 = 60;
MaxTsd_19.2 = 60;
MaxTsd_93.75 = 60;
MaxTsd_187.5 = 60;
MaxTsd_500 = 100;
MaxTsd_1.5M = 150;
MaxTsd_3M = 250;
Redundancy = 0;
Repeater_Ctr_Sig = 0;
24V_Pins = 0;

Freeze_Mode_supp = 1;
Sync_Mode_supp = 1;
Auto_Baud_supp = 1;
Set_Slave_add_supp = 1;
Usr_Prm_Data_Len = 0;
Min_Slave_intervall = 40;
Modular_Station = 1;
Max_Module = 2;
Max_Input_Len = 28;
Max_Output_Len = 28;
Max_Data_Len = 56;
Module = "PPO Typ 1 Module consistent PCD" 0xF3,
0xF1; EndModule;
Module = "PPO Typ 1 Word consistent PCD" 0xF3,
0x71; EndModule;
Module = "PPO Typ 2 Module consistent PCD" 0xF3,
0xF5; EndModule;
Module = "PPO Typ 2 Word consistent PCD" 0xF3,
0x75; EndModule;
Module = "PPO Typ 3 Module consistent PCD" 0xF1;
EndModule;
Module = "PPO Typ 3 Word consistent PCD" 0x71;
EndModule;
Module = "PPO Typ 4 Module consistent PCD" 0xF5;
EndModule;
Module = "PPO Typ 4 Word consistent PCD" 0x75;
EndModule;
Module = "PPO Typ 5 Module consistent PCD" 0xF3,
0xF9; EndModule;
Module = "PPO Typ 5 Word consistent PCD" 0xF3,
0x79; EndModule;

```



The VLT can also accept word consistency in the PCD modules, whereas the PCV portion must be module consistent.

VLT 2800: 3 MBaud

■ GSD-file

The GSD-file is a DP “standard” text file containing the necessary data for configuring DP slaves within a standard DP master.

GSD-file: DA010404.GSD

GSD-file for Danfoss VLT® 2800 Series with PROFIBUS

#Profibus_DP

Vendor_Name = „DANFOSS DRIVES A/S“;

Model_name = „VLT® SERIES 2800“;

Revision = „00“;

Ident_Number = 0x0404;

Protocol_Ident = 0;

Station_type = 0;

FMS_supp = 0;

Hardware_Release = „2.0“;

Software_Release = „1.00“;

9.6_supp = 1;

19.2_supp = 1;

93.75_supp = 1;

187.5_supp = 1;

500_supp = 1;

1.5M_supp = 1;

3M_supp = 1;

6M_supp = 0;

12M_supp = 0;

MaxTsdr_9.6 = 60;

MaxTsdr_19.2 = 60;

MaxTsdr_93.75 = 60;

MaxTsdr_187.5 = 60;

MaxTsdr_500 = 100;

MaxTsdr_1.5M = 150;

MaxTsdr_3M = 250;

Redundancy = 0;

Repeater_Ctr_Sig = 0;

24V_Pins = 0;

Freeze_Mode_supp = 1;

Sync_Mode_supp = 1;

Auto_Baud_supp = 1;

Set_Slave_add_supp = 1;

Usr_Prm_Data_Len = 0;

Min_Slave_Intervall = 10;

Modular_Station = 1;

Max_Module = 2;

Max_Input_Len = 28;

Max_Output_Len = 28;

Max_Data_Len = 56;

Max_Diag_Data_Len = 6;

Module = „PPO Typ 1 Module consistent PCD“ 0xF3, 0xF1;

EndModule;

Module = „PPO Typ 1 Word consistent PCD „ 0xF3, 0x71;

EndModule;

Module = „PPO Typ 2 Module consistent PCD“ 0xF3, 0xF5;

EndModule;

Module = „PPO Typ 2 Word consistent PCD „ 0xF3, 0x75;

EndModule;

Module = „PPO Typ 3 Module consistent PCD“ 0xF1;

EndModule;

Module = „PPO Typ 3 Word consistent PCD „ 0x71;

EndModule;

Module = „PPO Typ 4 Module consistent PCD“ 0xF5;

EndModule;

Module = „PPO Typ 4 Word consistent PCD „ 0x75;

EndModule;

Module = „PPO Typ 5 Module consistent PCD“ 0xF3, 0xF9;

EndModule;

Module = „PPO Typ 5 Word consistent PCD „ 0xF3, 0x79;

EndModule;



The VLT can also accept word consistency in the PCD modules, whereas the PCV portion must be module consistent.

VLT 2800: 12 MBaud

■ GSD-file

The GSD-file is a DP “standard” text file containing the necessary data for configuring DP slaves within a standard DP master.

GSD-file: DA010405.GSD
 GSD-file for Danfoss VLT® 2800 Series
 with PROFIBUS

```
#Profibus_DP
Vendor_Name = "DANFOSS DRIVES A/S";
Model_name = "VLT® 2800 12MB";
Revision = "00";
Ident_Number = 0x0405;
Protocol_Ident = 0;
Station_type = 0;
FMS_supp = 0;
Hardware_Release = "5.0";
Software_Release = "2.20";
9.6_supp = 1;
19.2_supp = 1;
93.75_supp = 1;
187.5_supp = 1;
500_supp = 1;
1.5M_supp = 1;
3M_supp = 1;
6M_supp = 1;
12M_supp = 1;
MaxTsdr_9.6 = 60;
MaxTsdr_19.2 = 60;
MaxTsdr_93.75 = 60;
MaxTsdr_187.5 = 60;
MaxTsdr_500 = 100;
MaxTsdr_1.5M = 150;
MaxTsdr_3M = 250;
MaxTsdr_6M = 450;
MaxTsdr_12M = 800;
Redundancy = 0;
Repeater_Ctr_Sig = 0;
24V_Pins = 0;
Freeze_Mode_supp = 1;
Sync_Mode_supp = 1;
```

```
Auto_Baud_supp = 1;
Set_Slave_add_supp = 1;
Usr_Prm_Data_Len = 0;
Min_Slave_Intervall = 06;
Modular_Station = 1;
Max_Module = 2;
Max_Input_Len = 28;
Max_Output_Len = 28;
Max_Data_Len = 56;
Max_Diag_Data_Len = 6;
Module = "PPO Typ 1 Module consistent PCD" 0xF3,
0xF1;
EndModule;
Module = "PPO Typ 1 Word consistent PCD " 0xF3,
0x71;
EndModule;
Module = "PPO Typ 2 Module consistent PCD" 0xF3,
0xF5;
EndModule;
Module = "PPO Typ 2 Word consistent PCD " 0xF3,
0x75;
EndModule;
Module = "PPO Typ 3 Module consistent PCD" 0xF1;
EndModule;
Module = "PPO Typ 3 Word consistent PCD " 0x71;
EndModule;
Module = "PPO Typ 4 Module consistent PCD" 0xF5;
EndModule;
Module = "PPO Typ 4 Word consistent PCD " 0x75;
EndModule;
Module = "PPO Typ 5 Module consistent PCD" 0xF3,
0xF9;
EndModule;
Module = "PPO Typ 5 Word consistent PCD " 0xF3,
0x79;
EndModule;
```



The VLT can also accept word consistency in the PCD modules, whereas the PCV portion must be module consistent.

■ **Eta-K and VLT 2800 parameters**

Only the PROFIBUS specific parameters (800 - 805 and 904 . .) are described in this manual. All other parameters and their functions are unaffected by the PROFIBUS option. We refer to the parameter description in the design guide on the Eta-K (MG.97.Gx.02) and the design guide on the VLT 2800 Series (MG.28.Ex.02).

Special attention must be given to the following parameters that are not described in this manual:

- 502 - 508: Selection of how to gate PROFIBUS control commands with control commands on the digital inputs of the Eta-K / VLT2800.
- 512: Control word profile, selects a control word according to PROFIDRIVE or a Danfoss specified control word.
- 515 - 543: Data readout parameters that can be used to read various actual data from the VLT, as for example actual status on the analog and digital inputs of the Eta-K / VLT 2800 thus using these as inputs to the master.

■ **PROFIBUS specific parameters**

800 Protocol select (PROTOCOL SELECT)

★ DP [1]

Function:

Selection of the PROFIBUS protocol supported by the master.

Description of selections:

- *DP*: Communication according to DIN 19245 part 3.



Updating parameter 800, even with an unchanged data value, will initialise the PROFIBUS option, meaning that all communication parameters such as slave addresses, PPO type etc. will be updated.

803 Bus time out (BUS TIME OUT)

Selection:

★ 1 - 99 sec 1 sec

804 Bus time out function (TIME OUT FUNCT.)

Selection:

★ Off (OFF)	[0]
Freeze output frequency (FREEZE OUTPUT)	[1]
Stop with auto restart (STOP)	[2]
Output frequency = JOG freq. (JOGGING)	[3]
Output freq. = Max. freq. (MAX SPEED)	[4]
Stop with trip (STOP AND TRIP)	[5]
Select Setup 2	[8]

Function:

The time out counter is triggered at the first reception of a valid control word i.e. bit 10 = ok, when DP is used.

The *time out* function can be activated in two different ways:

1. CTW is not updated within the time specified in parameter 803.
2. Time out is triggered if the CTW is not valid, see parameter 805.

The Eta-K / VLT 2800 remains in time out state until one of the following conditions is true:

1. Valid control word (Bit 10 = ok) is received. If *Stop with trip* is selected, reset must also be activated. If *Select setup 2* is selected, the Eta-K / VLT 2800 will remain in Setup 2 until parameter 4 is changed.
2. Parameter 804 = *Off* ⇒ control via PROFIBUS is resumed and the most recent control word is used.

Description of selections:

- *Freeze output frequency*: Freeze output frequency until communication is resumed.
- *Stop with auto restart*: Stop with auto restart when communication is resumed.
- *Output frequency = JOG freq.*: Motor will run at JOG frequency until communication is resumed.
- *Output frequency = Max. freq.*: Motor will run at max. frequency until communication is resumed.
- *Stop with trip*: Motor is stopped, reset needed for restart, see explanation above.
- Select setup 2.

★ *Factory setting*

805 Function of control word bit 10
(Bit 10 function)
Selection:

No function (NO FUNCTION)	[0]
★ Bit 10 = 1 ⇒ CTW active (BIT 10 = 1 ⇒ CTW ACTIVE)	[1]
Bit 10 = 0 ⇒ CTW active (BIT 10 = 0 ⇒ CTW ACTIVE)	[2]
Bit 10 = 0 ⇒ time out (BIT 10 = 0 ⇒ TIME OUT)	[3]

Function:

According to the PROFIDRIVE profile, control word and speed reference will be ignored if bit 10 of the control word is 0, but parameter 805 lets the user change the function of bit 10. This is some times necessary as some masters are setting all bits to 0 in various fault situations. In these cases it makes sense to change the function of bit 10 so that the Eta-K / VLT 2800 is commanded to stop (coast) when all bits are 0.

Description of selections:

- *Bit 10 = 1 ⇒ CTW active:* Control word and speed reference is ignored if bit 10 = 0.
- *Bit 10 = 0 ⇒ CTW active:* Control word and speed reference is ignored if bit 10 = 1. If all bits of the control word are 0 the Eta-K / VLT 2800 reaction will be coasting.
- *Bit 10 = 0 ⇒ time out:* The time out function selected in parameter 804 is activated when bit 10 is 0.
- *No function:* Bit 10 is ignored, i.e. control word and speed reference is always valid.

904 PPO type select for DP (PPO TYPE SELECT)
Selections:

★ PPO type 1 (PPO TYPE 1)	[900]
PPO type 2 (PPO TYPE 2)	[901]
PPO type 3 (PPO TYPE 3)	[902]
PPO type 4 (PPO TYPE 4)	[903]
PPO type 5 (PPO TYPE 5)	[905]

Function:

The selection is valid for read and write, i.e. the same PPO type must be used for read and write.

Description of selections:

- PPO type 1: 12 byte PPO with parameter channel for read and write of parameters and 4 bytes of process data (control/status word and reference/actual output frequency).
- PPO type 2: 20 byte PPO as PPO type 1 with 8 additional bytes of selectable process data.
- PPO type 3: 4 byte process data (control/status word and reference/actual output frequency).
- PPO type 4: 12 byte process data, as process data part of PPO type 2.
- PPO type 5: 28 byte as PPO type 2 with 8 additional bytes of selectable process data.

A detailed description of the PPO types can be found on page 23.



Change of parameter 904 is executed when parameter 800 is updated or at next power up.

915 PCD config. write (PCD IN WR-)
Selections:

Sub index 1 (PCD1)	Parameter #
Sub index 2	Parameter #
Sub index 3	Parameter #
Sub index 4	Parameter #
Sub index 5	Parameter #
Sub index 6	Parameter #
Sub index 7	Parameter #
Sub index 8	Parameter #

Function:

Different parameters can be assigned to PCD 1-8 of the PPO's (the number of PCD's depends on the PPO type). The values in PCD 1-8 will be written to the selected parameters as data values.

Write access via PROFIBUS or standard RS 485.

Description of selections:

The order of the subindexes corresponds to the order of the PCD's in the PPO, i.e. subindex 1 ≈ PCD 1, subindex 2 ≈ PCD 2 and so on. Each subindex can hold the number of the Eta-K / VLT 2800 parameters with write access, but it is only possible to write 2 byte values (least significant bytes) to parameters with 4 byte data values because 1 PCD consists of only 2 bytes.

916 PCD config. read (PCD IN RD-)
Selections:

Sub index 1 (PCD 1)	Parameter #
Sub index 2	Parameter #
Sub index 3	Parameter #
Sub index 4	Parameter #
Sub index 5	Parameter #
Sub index 6	Parameter #
Sub index 7	Parameter #
Sub index 8	Parameter #

Function:

Different parameters can be assigned to PCD 1-8 of the PPO's (the number of PCD's depends on the PPO type). PCD 1-8 will hold the actual data value of the selected parameters.

Write access via Profibus or standard RS 485.

Description of selections:

The order of the subindexes corresponds to the order of the PCD's in the PPO, i.e. subindex 1 ≈ PCD 1, subindex 2 ≈ PCD 2 and so on. Each subindex can hold the number of any of the Eta-K / VLT 2800 parameters, but it is only possible to read 2 byte values (least significant bytes) from parameters with 4 byte data values as 1 PCD consists of only 2 bytes.

917 Activate spontaneous messages
(SPONT. MES)
Selections:

★ Off (OFF)	[0]
On (ON)	[1]

Function:

The spontaneous messages function can be switched on if it is desired to make the Eta-K / VLT 2800 issue a message when a warning or an alarm comes up.



Unread spontaneous messages will be stored in a 16 elements FIFO buffer.

Description of selections:

- **OFF:** The Eta-K / VLT 2800 will not issue spontaneous messages or event notification in case of a warning or an alarm.
- **ON:** The Eta-K / VLT 2800 will issue a spontaneous message when warnings or alarms are coming up.

918 Station address (STATION ADDR)
Selections:

1-126
★ 0

Function:

All stations connected to the same bus must have a unique address. The station address can be set in parameter 918.



Change parameter 918 is executed at next power up and if parameter 800 is updated.

★ Factory setting

953 Warning parameter 1 (WARN. PARA)
Selections:

 Read only

Function:

A 16 bit bitstring where each bit is associated with a specific warning according to the list below.

Bit		Bit = "1" when:
0	LSB	Connection with DP-master is not ok
1		Not used
2		FDL (Field-bus Data link Layer) is not ok
3		Clear data command received
4		Actual value is not updated
5		Spontaneous message FIFO overflow
6		PROFIBUS ASIC is not transmitting
7		Initialising of PROFIBUS option is not ok
8		Not used
9		Not used
10		Not used
11		Not used
12		Fatal DPR-handling error/Error code during init.: Bit 0
13		Fatal DPR-handling error/Error code during init.: Bit 1
14		Fatal DPR-handling error/Error code during init.: Bit 2
15	MSB	Fatal DPR-handling error/Error code during init.: Bit 3

 Explanation of error codes:

If init. went wrong (bit 7 asserted) following codes are defined:

Code	
0	OK
1	Init. channel not empty
2	No resp. on command „Init SPC3 controller“
3	No resp. on command „No action“
4	No resp. on writing init.-data
5	No valid resp. on writing init.-data
6	No positive resp. on writing init.-data

If errors occur during DPR-handling (bit 7 not asserted)

 Code

 0 OK

 1 Fatal error in warning channel

 2 Fatal error in spontaneous channel

 3 Fatal error in channel for input of process data

 4 Fatal error in channel for output of process data

 5 Fatal error in parameter channel 1

 6 Fatal error in parameter channel 2

 7 Fatal error in parameter channel 3

 15 Fatal error in DPR form SPC3

967 Control word
Selections:

 16 bits binary code

See page 22.

968 Status word
Selections:

 Read only

See page 22.

970 Edit set up selection (EDIT SETUP SELECT)

Selections:

Factory setup	(FACTORY SETUP)	[0]
Setup 1	(SETUP 1)	[1]
Setup 2	(SETUP 2)	[2]
★ Active setup	(ACTIVE SETUP)	[5]

Function:

As parameter 005, described in the Eta-K design guide (MG.97.Gx.02) and the VLT 2800 design guide (MG.28.Ex.02).

971 Store data values (STORE DATA VALUE)

Selections:

★ No action	(NO ACTION)	[0]
Store active setup	(STORE ACTIVE SETUP)	[1]
Store edit setup	(STORE EDIT SETUP)	[2]
Store all setups	(STORE ALL SETUPS)	[3]

Function:

Parameter values changed via PROFIBUS is only stored in RAM meaning that the changes are lost at power down. This parameter is used to activate a function that stores all parameter values in the EEPROM thus retaining changed parameter values at power down.

Description of selections:

No action: The store function is inactive.
Store active setup: All parameter values in the active setup will be stored in the EEPROM. The value returns to *No action* when all parameter values have been stored.
Store edit setup: All parameter values in the setup you are editing will be stored in the EEPROM. The value returns to *No action* when all parameter values have been stored.
Store all setups: All parameter values in both setups will be stored in the EEPROM. The value returns to *No action* when all parameter values have been stored.

980-982 Defined parameters (DEFINED PNU'S)

Selections:

Read only

Function:

The three parameters hold a list of all the parameters that are defined in the Eta-K / VLT 2800. It is possible to read single elements of the list by DP by using the corresponding subindex. The subindexes start at 1 and follow the order of the parameter numbers.

Each parameter holds up to 116 elements (parameter numbers).

When a 0 is returned as parameter number the list ends.

990-992 Modified parameters (MODIFIED PNU'S)

Selections:

Read only

Function:

The three parameters hold a list of all the Eta-K / VLT 2800 parameters that have been changed from factory setting. It is possible to read single elements of the list by DP by using the corresponding subindex. The subindexes start at 1 and follow the order of the parameter numbers. Each parameter holds up to 116 elements (parameter numbers). The number of parameters (990, 991 and 992) in use depends on how many parameters have been changed from factory setting.

Read only parameters, as for example data read out parameters, will not be registered as modified even though they are changing.

When a 0 is returned as parameter number the list ends.

★ *Factory setting*

■ Warning and alarm messages

There is a clear distinction between alarms and warnings. In the case of an alarm, the Eta-K / VLT 2800 will enter a fault condition. After the cause for the alarm has been cleared, the master will have to acknowledge the alarm message for the Eta-K / VLT 2800 to start operating again. A warning, on the other hand may come when a warning condition appears, and disappear when conditions return to normal without interfering with the process.

Warnings

Any warning within the Eta-K / VLT 2800 is represented by a single bit within a warning word. A warning word is always an active parameter. Bit status FALSE [0] means no warning, while bit status TRUE [1] means warning.

Any bit change in the warning word will result in a Spontaneous message being issued.

In addition to the warning word message the master will also be notified through a change of bit 7 in the Status Word.

Alarms

Following an Alarm message the Eta-K / VLT 2800 will enter Fault condition. Only after the fault has been alleviated and the master has acknowledged the alarm message by setting bit 7 in the Control word, can the Eta-K / VLT 2800 resume operation.

Any alarm within the Eta-K / VLT 2800 is represented by a single bit within an alarm word. An alarm word is always an action parameter. Bit status FALSE [0] means no fault, while bit status TRUE [1] means fault.

Any bit change in the alarm word will result in a Spontaneous message being issued.

■ Spontaneous messages

If a fault or warning condition should occur, the Eta-K / VLT 2800 will, if the proper communicative relationship has been established, issue a Spontaneous message to communication partners. Instead of responding to the master's request, the Eta-K / VLT 2800 will exchange the requested response with the alarm or the warning message.

Warnings and alarms will trigger a Spontaneous message. The same is true with any change to an active parameter.

■ Abbreviations

English	German	Elaboration
ACI	-	Acyclical Control Interval
ALI	-	Application Layer Interface
ATTR	-	Attribute
BRCT	-	Broadcast
CCI	-	Cyclical Control Interval
CR	KR	Communication Reference
CRL	KBL	Communication Reference List
CSRD	-	Cyclical Send and Request Data
CT	Typ	Connection Type
CTW	STW	Control Word
DA	-	Destination Address
DP	-	Distributed Periphery
EIA	-	Electronic Industries Association: Specifiers of the EIA Standard RS 485-A
EMC	EMV	Electromagnetic Compatibility
EN	-	Event Notification
FIFO	-	First In First Out
HSA	-	Highest Station Address
Hd	-	Hamming distance
HPFB	-	High Performance Field Bus
IND	-	Subindex
I/O	E/A	Input/Output
ISO	-	International Standards Organization
IR	-	Information Report
LSAP	-	Local Service Access Point
LSB	-	Least Significant Bit
MSB	-	Most Significant Bit
MAP	-	Manufacturing Automation Protocol
MAV	HIW	Main Actual Value
MMS	-	Manufacturing Message Specification
MRV	HSW	Main Reference Value
MSAC	MZAC	Master-Slave connection for acyclical transmission
MSAC_SI	MZAC_SI	Master-Slave connection for acyclical transmission with slave initiative
MSCY	MSZY	Master-Slave connection for cyclical transmission
MSCY_SI	MSZY_SI	Master-Slave connection for cyclical transmission with slave initiative
MULT	-	Multicast
OD	OV	Object Directory
PC	-	Personal Computer
PCA	PKE	Parameter Characteristics
PCD	PZD	Process Data
PCV	PKW	Parameter-Characteristics-Value
PDU	-	Protocol Data Unit
PLC	SPS	Programmable Logic Control
PNU	-	Parameter Number
PPO	-	Parameter-Process Data Object
PVA	PWE	Parameter Value
RAC	-	Receive Acknowledged request Counter
RADR	-	Remote Address
RC	AK	Request/Response Characteristics
RCC	-	Receive Confirmed request Counter
RSAP	-	Remote Service Access Point

English	German	Elaboration
SAC	-	Send Acknowledged request Counter
SAP	-	Service Access Point
SCC	-	Send Confirmed request Counter
SPM	-	Spontaneous Notification
STW	ZSW	Status Word
TRT	-	Target Rotation Time
VDE	-	Association of German Electrical Technicians
VDI	-	Association of German Electrical Engineers
VSD	FU	Variable Speed Drive

PNU #	Parameter Designation	Default value	Range	Size index ¹⁾	Conversion index ¹⁾	Data type ²⁾
800	Protocol select	1		0	0	5
803	Bus time out	1		4	0	5
804	Bus time out function	0		0	0	5
805	Bit 10 function	1		0	0	5
904	PPO type select	900	900-903	0	0	6
915	PCD config. write	0		0	0	6
916	PCD config. read	0		0	0	6
917 ⁴⁾	Spontaneous messages	OFF (0)	ON/OFF	0	0	35
918	Station address	0	1-126	0	0	6
967	Control word	0	16 bits	0	0	35
968	Status word		16 bits	0	0	35
970	Edit setup	5	0 - 6	0	0	6
971 ⁵⁾	Store data values	OFF (0)	ON/OFF	0	0	6*
980	Defined parameters			0	0	6
981						
982						
990	Modified parameters			0	0	6
991						
992						

* Automatic reset to (0).

⁴⁾ Available in all 4 setups.

⁵⁾ Only in stop mode

¹⁾ See table on page 18

Conversion index:

This number refers to a conversion figure to be used when writing or reading by means of a VLT frequency converter.

²⁾ See table on page 19

<p>A</p> <p>Abbreviations 35</p> <p>About this manual 3</p> <p>Assumptions 3</p> <p>B</p> <p>Bus topology 13</p> <p> Single master operation with DP 13</p> <p>C</p> <p>Cable lengths 5</p> <p>Control word 22</p> <p>Cyclical transmission 14</p> <p>D</p> <p>DP communication relations 16</p> <p>E</p> <p>EMC precautions 7, 10</p> <p>F</p> <p>FC motor parameters 29</p> <p>Features and services 14</p> <p>Features of DP 13</p> <p> Closing the control loop outside the fieldbus .. 14</p> <p> Closing the control loop over the bus 14</p> <p>G</p> <p>General information 4</p> <p>GSD-file 26, 27, 28</p> <p>L</p> <p>LED 9, 12</p> <p>M</p> <p>Master controlled Variable Speed Drives 5</p> <p> Communication partners 5</p> <p>N</p> <p>number of nodes 5</p> <p>O</p> <p>Object and data types 19</p> <p> Bit sequence 19</p> <p> Data coding 19</p> <p> Standardized value 19</p> <p> Time difference 19</p> <p>P</p> <p>Parameter and data type structure description ... 18</p> <p> Size attribute 18</p> <p>Parameter list 37</p>	<p>PCA - Parameter Characteristics 23</p> <p>PCA handling 17</p> <p>PCD 24</p> <p>PCV 23</p> <p>Physical connection 7, 10</p> <p> bus termination 8, 11</p> <p> Cable routing 7, 10</p> <p> Connecting the bus line 7, 10</p> <p> Earth connection 10</p> <p>PPO description 16</p> <p>PROFIBUS specific parameters 29</p> <p> Activate spontaneous messages 31</p> <p> Bus time out 29</p> <p> Bus time out function 29</p> <p> Control word 32</p> <p> Defined parameters 33</p> <p> Edit set up selection 33</p> <p> Function of control word bit 10 30</p> <p> Modified parameters 33</p> <p> PCD config. read 31</p> <p> PCD config. write 31</p> <p> PPO type select for DP 30</p> <p> Protocol select 29</p> <p> Station address 31</p> <p> Status word 32</p> <p> Store data values 33</p> <p> Warning parameter 1 32</p> <p> error codes 32</p> <p>Q</p> <p>Quick Setup 4</p> <p>R</p> <p>response time 15</p> <p>S</p> <p>SPM execution 20</p> <p>Spontaneous messages 19, 34</p> <p>status word 22</p> <p>Synchronize and freeze 20</p> <p> FREEZE/UNFREEZE 21</p> <p>System update time 15</p> <p>U</p> <p>unit classification 14</p> <p>W</p> <p>Warning and alarm messages 34</p> <p> Alarms 34</p> <p> Warnings 34</p> <p>What you should already know 3</p>
---	--