

CI-tronic™ Soft start motor controller

Type MCI 3, MCI 15, MCI 25, MCI 30 I-O, MCI 40-3D and MCI 50-3 I-O

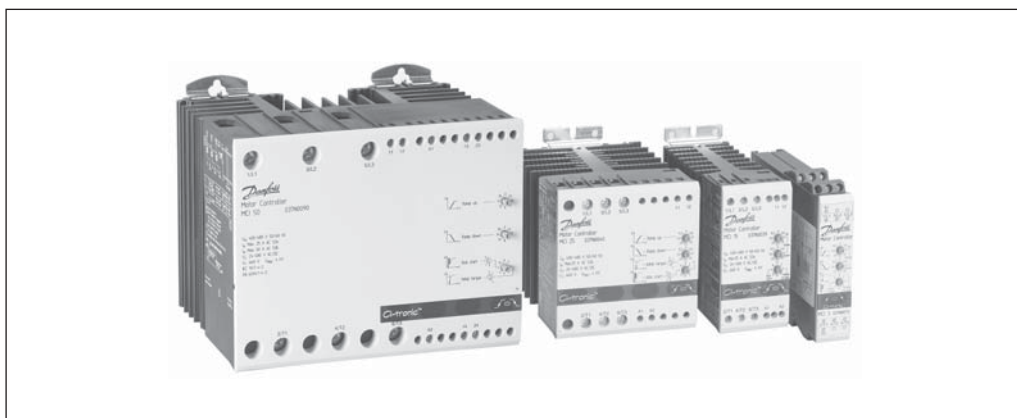

Features

- Motor load max. 50 A
- Acceleration times adjustable:
0-10 seconds, MCI 3, MCI 15 and MCI 25
0-20 seconds, MCI 30 I-O
0-30 seconds, MCI 40-3D I-O, MCI 50-3 I-O
- Deceleration times adjustable:
0-10 seconds, MCI 3, MCI 15, and MCI 25
0-20 seconds, MCI 30 I-O
0-60 seconds, MCI 40-3D I-O, MCI 50-3 I-O
- Initial torque adjustable up to 85 %
- Breakaway function (kick start)
- Universal control voltage:
24 - 480 V a.c./d.c.
- Automatic detection of missing phases
- Automatic adaptation to 50/60 Hz
- Optional auxiliary contacts
- LED Status indication
- Unlimited start/stop operations per hour
- Built in varistor protection
- Compact modular design
- DIN rail mountable
- EN 60947-4-2
- CE and cUL_{US} (UL 508)

Description

The MCI soft starters are designed for soft starting and stopping of 3 phase a.c. motors, thus reducing the inrush current and eliminating the damaging effects of high starting torque surges.

The digitally controlled soft starter features accurate settings and easy installation. The controller has individually adjustable acceleration and deceleration times.

Thanks to the adjustable initial torque and the unique breakaway (kick start) function the soft starter can be optimized for almost any application.

The MCI soft starters are typically used on motor applications where a smooth start and/or stop is advantageous, such as conveyors, fans, pumps, compressors and high inertia loads. MCI soft starters are also obvious as replacement for star/delta starters.

Adjustments

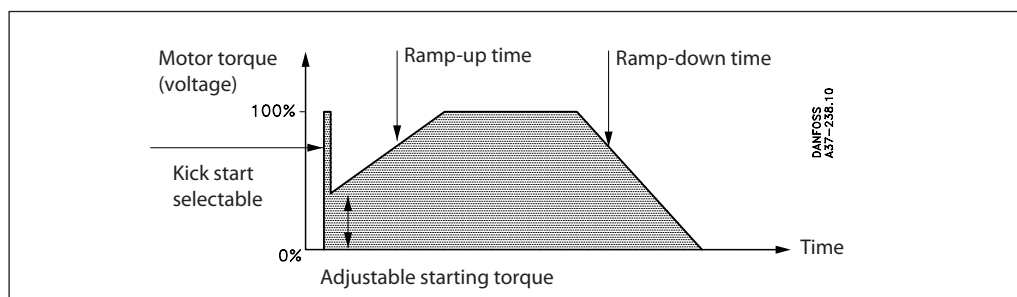

Selection guide

Operational voltage	Motor current max.	Motor power max.	Dimensions	Type	Aux. contacts	Code no.
208 - 240 V a.c.	3A	0.7 kW / 1 HP	22.5 mm module	MCI 3	-	037N0073
208 - 240 V a.c.	15A	4.0 kW / 5.5 HP	45 mm module	MCI 15	-	037N0037
208 - 240 V a.c.	25A	7.5 kW / 10 HP	90 mm module	MCI 25	-	037N0038
208 - 240 V a.c.	25A (30A)*	11 kW / 15 HP*	90 mm module	MCI 30 I-O	I-O, bypass	037N0069
208 - 240 V a.c.	35A (50A)*	15 kW / 20 HP*	180 mm module	MCI 50-3 I-O	I-O, bypass	037N0089
380 - 415 V a.c.	3A	1.5 kW / 2 HP	22.5 mm module	MCI 3	-	037N0074
440 - 480 V a.c.	3A	1.5 kW / 2 HP	22.5 mm Module	MCI 3	-	037N0084
380 - 480 V a.c.	15A	7.5 kW / 10 HP	45 mm module	MCI 15	-	037N0039
380 - 480 V a.c.	25A	11 kW / 15 HP	90 mm module	MCI 25	-	037N0040
380 - 480 V a.c.	25A (30A)*	15 kW / 20 HP*	90 mm module	MCI 30 I-O	I-O, bypass	037N0070
380 - 480 V a.c.	29A (43A)*	21 kW / 28 HP*	90 mm module	MCI 40-3D I-O	I-O, bypass	037N0092
380 - 480 V a.c.	35A (50A)*	22 kW / 30 HP*	180 mm module	MCI 50-3 I-O	I-O, bypass	037N0090
500 - 600 V a.c.	3A	2.2 kW / 3 HP	22.5 mm module	MCI 3	-	037N0075
500 - 600 V a.c.	15A	7.5 kW / 10 HP	45 mm module	MCI 15	-	037N0041
500 - 600 V a.c.	25A	15 kW / 20 HP	90 mm module	MCI 25	-	037N0042
500 - 600 V a.c.	25A (30A)*	18.5 kW / 25 HP*	90 mm module	MCI 30 I-O	I-O, bypass	037N0071
500 - 600 V a.c.	35A(50A)*	30 kW / 40 HP*	180 mm module	MCI 50-3 I-O	I-O, bypass	037N0091

* If used with bypass contactor

Technical data

Output Specification	MCI 3	MCI 15	MCI 25	MCI 30 I-O	MCI 40-3D I-O	MCI 50-3 I-O
Operational current max.	3A	15A	25A	30A (if bypassed during steady state)	43A (if bypassed during steady state)	50A (if bypassed during steady state)
Motor size at: 208 - 240 V a.c. 380 - 480 V a.c. 500 - 600 V a.c.	0.1-0.7 kW (0.18-1 HP) 0.1-1.5 kW (0.18-2 HP) 0.1-2.2 kW (0.18-3 HP)	0.1-4.0 kW (0.18-5.5 HP) 0.1-7.5 kW (0.18-10 HP) 0.1-7.5 kW (0.18-10 HP)	0.1-7.5 kW (0.18-10 HP) 0.1-11 kW (0.18-15 HP) 0.1-15 kW (0.18-20 HP)	0.1-11 kW (0.18-15 HP) 0.1-15 kW (0.18-20 HP) 0.1-18.5 kW (0.18-25 HP)	0.1-21 kW (0.18-28 HP)	0.1-15 kW (0.18-20 HP) 0.1-22 kW (0.18-30 HP) 0.1-30 kW (0.18-40 HP)
Leakage current max	5 mA					
Min. operational current	50 mA					
Overload relay trip class	Class 10 10					
Semiconductor protection Type 1 co-ordination Type 2 co-ordination I ² t (t = 10ms)	25A gL/gG 72 A ² s	50 A gL/gG 1800 A ² s	80 A gL/gG 6300 A ² s	80 A gL/gG 6300 A ² s	80 A gL/gG 6300 A ² s	125 A gL/gG 25300 A ² s
Rating index: AC-53a Asynchronous motors AC-53b Asynchronous motors with bypass AC-58a Hermetic refrigeration compressors	- 3A : AC-53b : 5-5 : 10 -	15A: AC-53a: 8-3:100-3000 - 15A: AC-58a: 6-6: 100-3000	25A: AC-53a: 6-5: 100-480 - 25A: AC-58a: 6-6: 100-480	25A: AC-53a: 6-5: 100-480 30A: AC-53b: 5-5: 30 25A: AC-58a: 6-6: 100-480	29A: AC-53a: 6-5: 100-120 43A: AC-53b: 5-5: 30	35A: AC-53a: 6-6: 00-120 50A: AC-53b: 6-6: 30 -

Control Circuit Specifications

Control voltage range	24 - 480 V a.c./d.c.					
Pick-Up voltage max.	20.4 V a.c./d.c.					
Drop-out voltage min.	5 V a.c./d.c.					
Max. control current for no operation	1 mA					
Control current / Power max.	15 mA / 2 VA					
Response time max.	70 ms					
Ramp -up time	adjust. from 0-10 seconds			0-20 seconds	0-30 seconds	
Ramp-down time	adjust. from 0-10 seconds			0-20 seconds	0-60 seconds	
Initial Torque	adjust. from 0-85 % of nominal torque with optional kick start					
SCR Aux. contacts, opt. Voltage/current max. (AC-14, AC-15)	24-480 V a.c. / 0.5 A					24-480 V a.c./1.0 A
Fuse max. I ² t (t = 10ms)	10 A gL/gG, I2t max. 72 A ² s					
EMC immunity and emission	Meets requirements of EN 60947-4-2					

Insulation

Rated installation voltage, U _i	660 V AC
Rated impulse withstand voltage, U _{imp} V	4 k
Installation Category	III

Technical data (continued)

Thermal specifications

	MCI 3	MCI 15	MCI 25	MCI 30 I-O	MCI 40-3D I-O	MCI 50-3 I-O
Power dissipation*), continuous duty max.:	4 W	2 W/A			3 W/A	
Power dissipation*), Intermittent duty max.:	4 W	2 W/A x duty cycle			3 W/A x duty cycle	
Ambient temperature range	-5°C to 40°C					
Cooling method	Natural convection					
Mounting	Vertical +/- 30°					
Max. ambient temperature with limited rating	60°C, see derating for high temperatures in chart page 6					
Storage temp. range	-20°C to 80°C					
Protection degree/pollution degree	IP 20 / 3					IP 10 / 3

Materials

Housing	Self extinguishing PPO UL94V1
Heatsink	Aluminum black anodized
Base	Electroplated steel

*) If used without a bypass contactor

Functional diagram

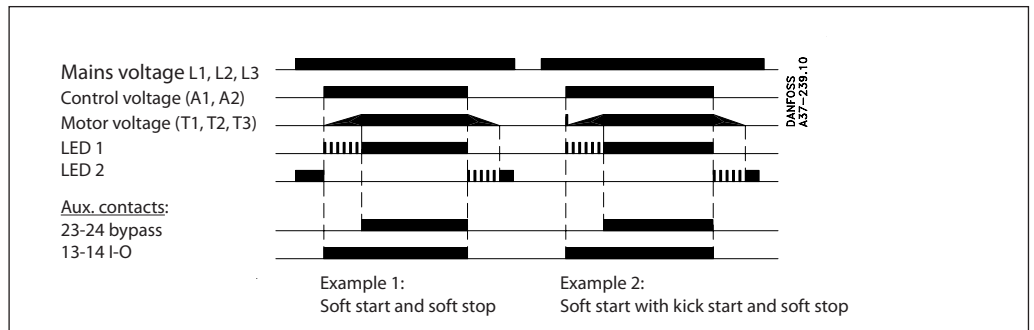

Functional description

Ramp up

During ramp-up the controller will gradually increase the voltage to the motor until it reaches full line voltage. The motor speed will depend on the actual load on the motor shaft. A motor with little or no load will reach full speed before the voltage has reached its maximum value. The actual ramp time is digitally calculated and will not be influenced by other settings, net frequency or load variations.

Initial torque

The initial torque is used to set the initial starting voltage. This way it is possible to adapt the controller to an application requiring a higher starting torque. In some cases on application with very high break-away torque the initial torque can be combined with a kick start function. The kick start is a period of 200 ms where the motor receives full voltage.

Soft stop

During ramp-down the controller will gradually reduce the voltage to the motor thus reducing

the torque and current. As a consequence the motor speed will fade off. The soft stop feature is advantageous to avoid liquid hammering and cavitation on pumps, and to avoid goods tilting on conveyors.

Auxiliary contacts, optional

The auxiliary contacts are made possible by means of SCR technology and will only switch correctly on a.c. current.

I-O contact (13 - 14):

The contact will be closed as long as the controller receives a control voltage, see functional diagram

Bypass contact (23 - 24):

The contact is intended for operating an external bypass contactor. The contact will close when the controller is in steady state operation, see functional diagram.

LED status indication

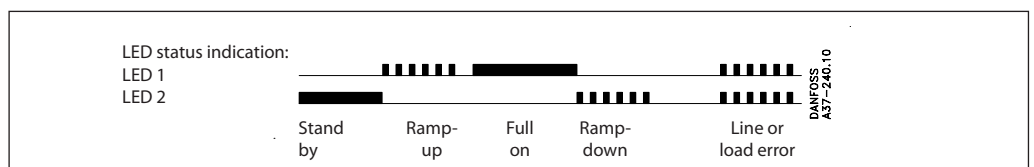

Wiring

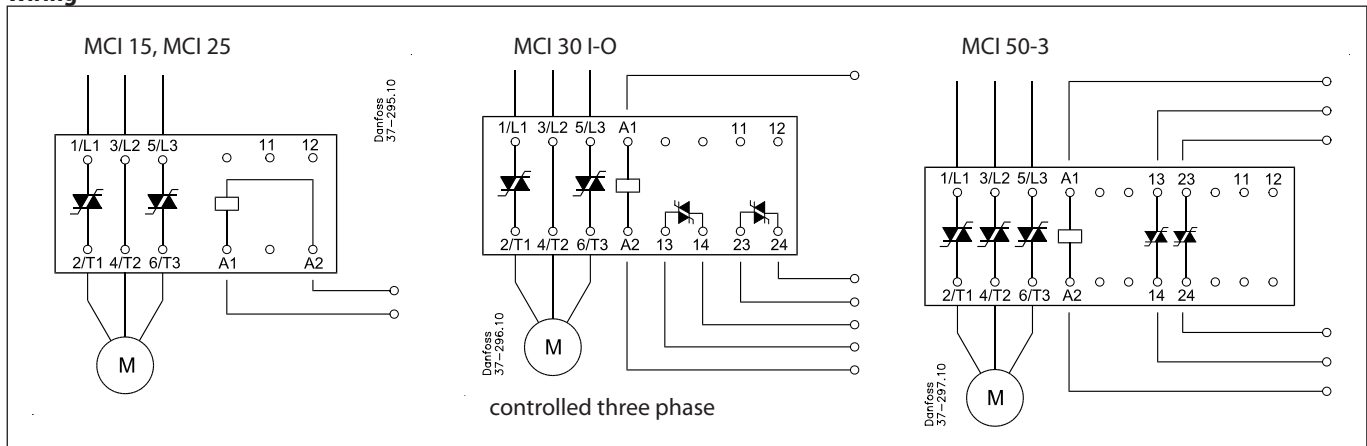

Overload and Short Circuit Protection

Overload and short circuit protection is easily achieved by installing a circuit breaker on the line side of the soft starter. Select the circuit breaker from the table according to motor full load current.

Be aware of the maximum prospective short circuit current breaking capacity. For further information please refer to the data sheet on the circuit breaker.

380-415 V a.c.					
Motor full load current in A	Soft starter Type	Soft starter I ² t value	Circuit breaker Type	Circuit breaker Code no.	Max. prospective short-circuit current I _{cc} for co-ordination 2
0.40 - 0.63	MCI 15	1800 A ² s	CTI 25M	047B3143	100 kA
0.63 - 1.0	MCI 15	1800 A ² s	CTI 25M	047B3144	100 kA
1.0 - 1.6	MCI 15	1800 A ² s	CTI 25M	047B3145	100 kA
1.6 - 2.5	MCI 15	1800 A ² s	CTI 25MB	047B3153	100 kA
2.5 - 4.0	MCI 15	1800 A ² s	CTI 25MB	047B3154	100 kA
4 - 6.3	MCI 15	1800 A ² s	CTI 25MB	047B3155	4 kA
6.3 - 10	MCI 15	1800 A ² s	CTI 25MB	047B3156	1.5 kA
10 - 16	MCI 15	1800 A ² s	CTI 25MB	047B3157	2.5 kA*)
14.5 - 20	MCI 25/30 I-O	6300 A ² s	CTI 25MB	047B3158	1.8 kA
18 - 25	MCI 25/30 I-O	6300 A ² s	CTI 25MB	047B3159	1.5 kA
18 - 25	MCI 25/30 I-O	6300 A ² s	CTI 45MB	047B3163	1.3 kA
23 - 32	MCI 50 I-O	25300A ² s	CTI 45MB	047B3164	6 kA
32 - 45	MCI 50 I-O	25300A ² s	CTI 45MB	047B3165	4 kA
40 - 63	MCI 50 I-O	25300A ² s	CTI 100	047B3014	5 kA

*)Type 2 co-ordination can only be achieved with MCI 25

Dimensions mm (inch)

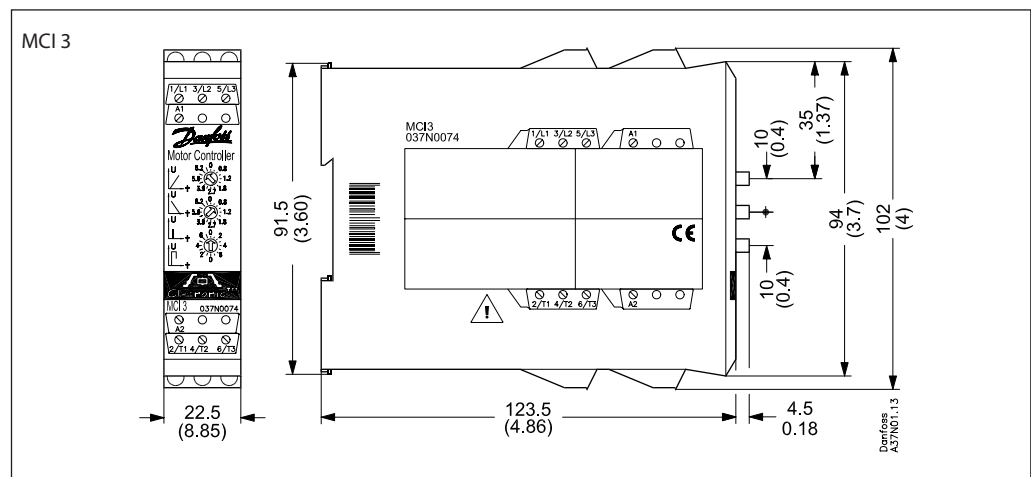

Dimensions
mm (inch)

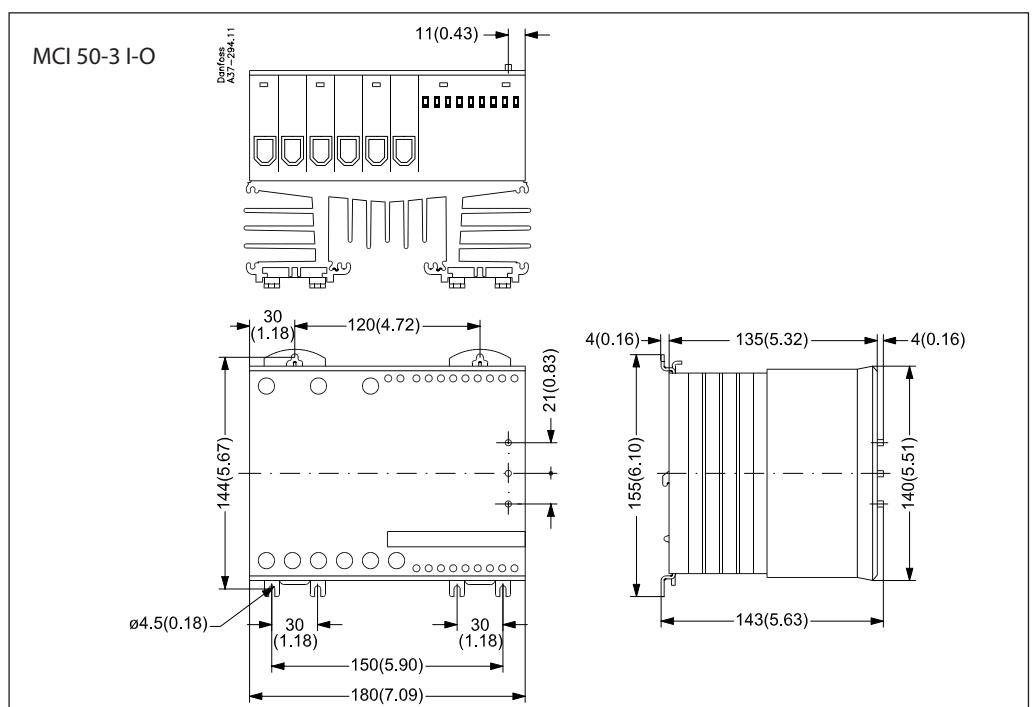
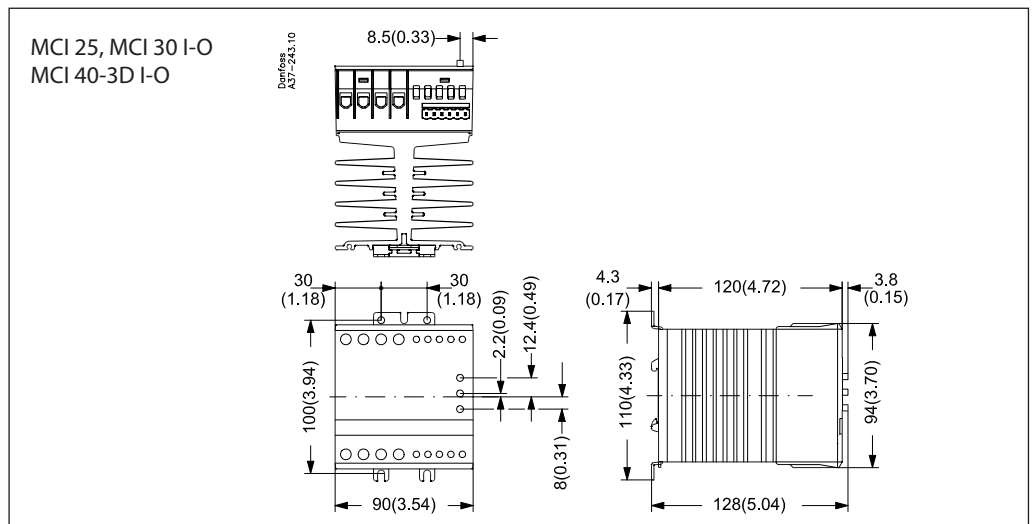
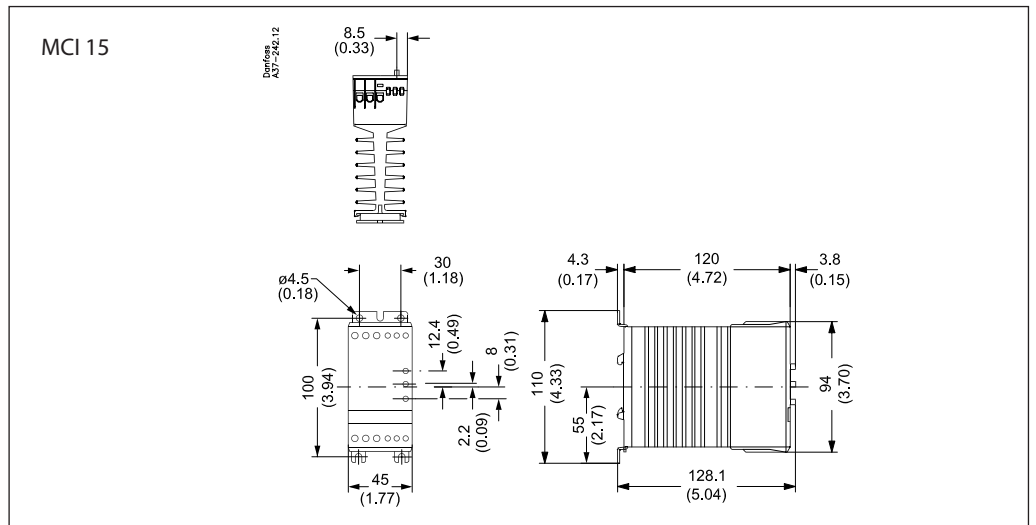

Operation at high temperatures

If soft starter is used without external bypass contactor:

Ambient temperature	Continuous current					
	MCI 3	MCI 15	MCI 25	MCI 30 I-O	MCI 40-3D I-O	MCI 50-3 I-O
40°C	3 A	15 A	25 A	25 A	29 A	35 A
50°C	2.5 A*	12.5 A	20 A	20 A	23 A	30 A
60°C	2.0 A*	10 A	17 A	17 A	20 A	25 A

* Minimum 10 mm side clearance between products

Ambient temperature	Duty-cycle rating (15 min. max. on-time)				
	MCI 15	MCI 25	MCI 30 I-O	MCI 40-3D I-O	MCI 50-3 I-O
40°C	15 A (100% duty-cycle)	25 A (100% duty-cycle)	25 A (100% duty-cycle)	43 A (65% duty-cycle)	50 A (65% duty-cycle)
50°C	15 A (80% duty-cycle)	25 A (80% duty-cycle)	25 A (80% duty-cycle)	43 A (50% duty-cycle)	50 A (55% duty-cycle)
60°C	15 A (65% duty-cycle)	25 A (65% duty-cycle)	25 A (65% duty-cycle)	43 A (40% duty-cycle)	50 A (45% duty-cycle)

If soft starter is used with external bypass contactor:

Ambient temperature	Continuous current				
	MCI 15	MCI 25	MCI 30 I-O	MCI 40-3D I-O	MCI 50-3 I-O
40°C	15	25	30	43	50
50°C	15	25	30	43	50
60°C	15	25	30	43	50

Over heat protection

If required the controller can be protected against overheating by inserting a thermostat in the slot on the right-hand side of the controller.

Order: UP 62 thermostat **037N0050**

Depending on the application the thermostat can be connected in series with the control circuit of the main contactor. When the temperature of the heat sink exceeds 90°C the main contactor will be switched OFF. A manual reset is necessary to restart this circuit. For wiring connections see application examples page 7.

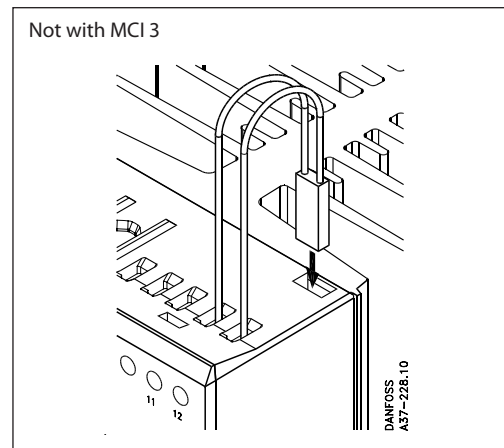

Mounting Instructions

The controller is designed for vertical mounting. If the controller is mounted horizontally the load current must be reduced by 50%.

The controller needs no side clearance.

Clearance between two vertical mounted controller must be minimum 80 mm (3.15").

Clearance between controller and top and bottom walls must be minimum 30 mm (1.2").

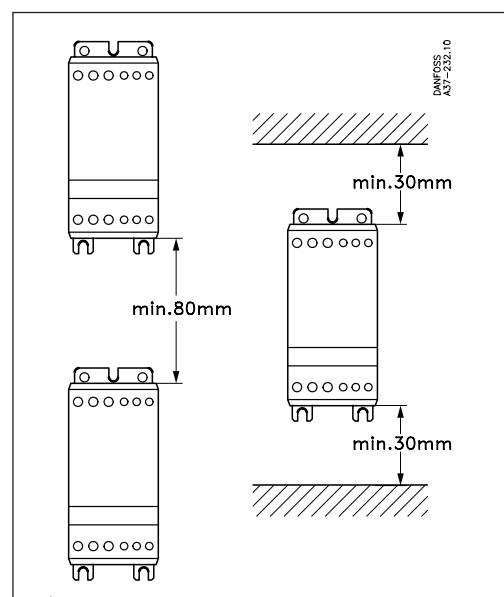

Application examples

Overheat protection

Example 1

The thermostat can be connected in series with the control input of the soft starter. When the temperature of the heat sink exceeds 90°C the soft starter will be switched OFF.

NOTE when the temp. has dropped approx. 30°C the controller will automatically be switched ON again. This is not acceptable in some applications.

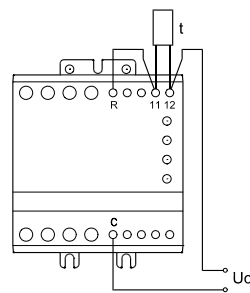

Example 2

The thermostat is connected in series with the control circuit of the main contactor. When the temp. of the heat sink exceeds 90°C the main contactor will be switched OFF. This circuit requires manual reset to restart the motor.

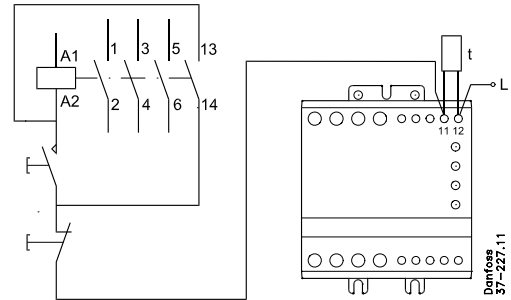

Line Controlled Soft start

When the contactor C1 is switched to the ON-State, the soft starter will start the motor, according to the settings of the Ramp-up time and Initial torque adjustments.

When the contactor C1 is switched to the OFF-State the motor will be switched off instantaneously.

In this application the contactor will have no load during making operation. The contactor will carry and break the nominal motor current.

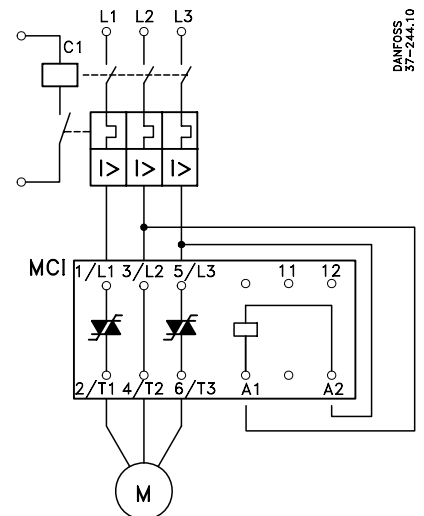

Application examples
Cont.

Input controlled soft start

When the control voltage is applied to A1 - A2, the MCI soft starter will start the motor, according to the settings of the Ramp-up time and Initial torque adjustments.

When the control voltage is switched OFF, the motor will be soft stopped according to the settings of the Ramp-down time adjustment.

To switch off instantaneously set the Ramp-down time to 0.

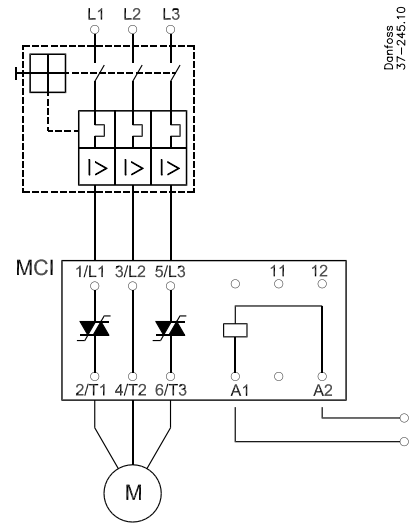

Danfoss
37-245,10

Combined reversing contactor and soft starter

Soft Start & Soft Stop

A soft-reversing of a motor can easily be achieved by connecting a reversing contactor to the soft starter. The reversing contactor, type RCI, will determine the direction of rotation, forward or reverse and the soft starter, type MCI, will perform soft-starting and soft-stopping of the motor.

Soft Start only

If soft-stop is not required the application can be simplified by connecting the control circuit, of the soft starter, to the main terminals as shown under Line controlled Soft-Start (see example on page 7).

A delay of approx. 0.5 sec. between forward and reverse control signal must be allowed to avoid influence from the voltage generated by the motor during turn-off.

Instead of the electronic reversing contactor, type RCI, an electromechanical reversing contactor can be applied. Due to the soft starter the reversing contactor will not be exposed to high inrush currents. As a result a longer life time of the electromechanical contactor can be expected.

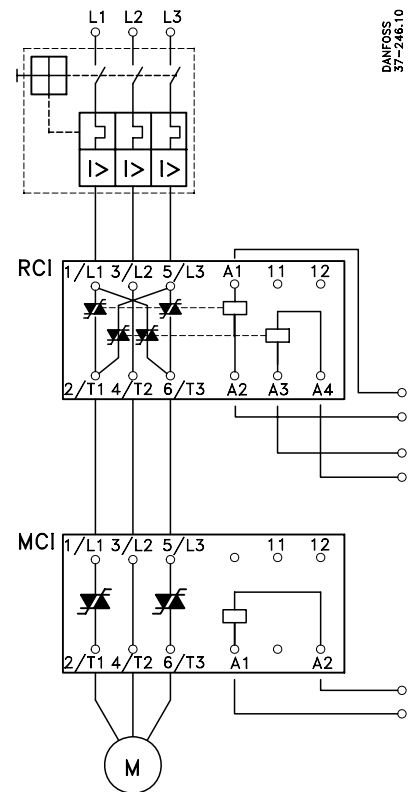

Danfoss
37-246,10

Application examples
Cont.)

MCI with bypass contactor

If the MCI soft starter is bypassed during steady state operation there is no heat dissipation. A bypassed MCI can be loaded according to tabel page 6: "Operating at high temperatures".

As the contactor always switches in after end of ramp up time it can be selected on the basis of the thermal current (AC-1).

By means of the integrated auxiliary contact the bypass function is easily achieved. See wiring diagram below and "Functional diagram" page 3.

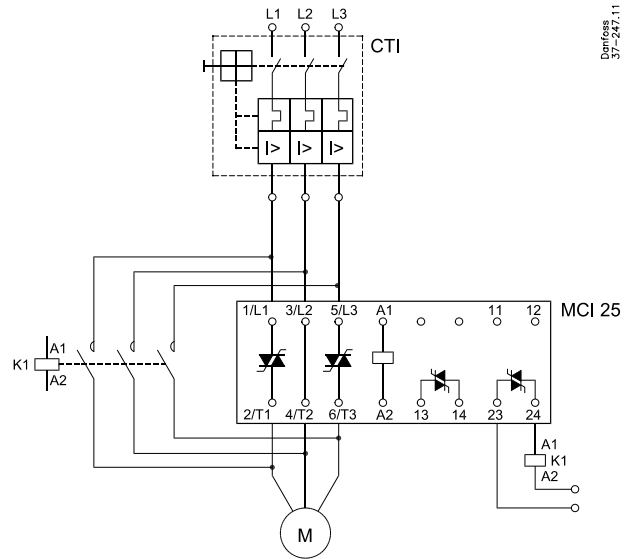

**MCI 40-3D I-O
Inside - delta motor configuration**

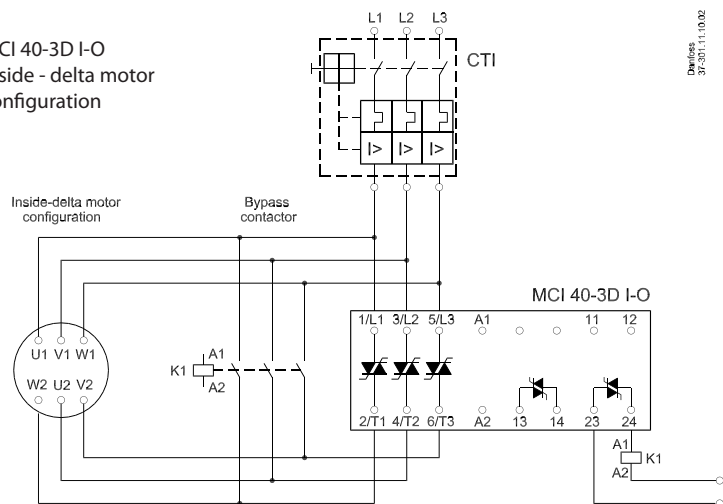

Danfoss can accept no responsibility for possible errors in catalogues, brochures and other printed material. Danfoss reserves the right to alter its products without notice. This also applies to products already on order provided that such alterations can be made without subsequential changes being necessary in specifications already agreed. All trademarks in this material are property of the respective companies. Danfoss and the Danfoss logotype are trademarks of Danfoss A/S. All rights reserved.