



# Instruction

HPFB



VLT® 5000  
VLT® 5000 FLUX  
VLT® 6000 HVAC  
VLT® 8000 AQUA



---

## High Performance FieldBus cards

---

Profibus card VLT 5000/5000 Flux/6000 HVAC/8000 AQUA .....	3
Interbus card VLT 5000 .....	6
DeviceNet card VLT 5000/5000 Flux/6000 HVAC/8000 AQUA .....	8
Modbus+ card VLT 5000 .....	10
Modbus RTU card .....	12
Lonworks card VLT 5000/6000 HVAC/8000 AQUA Free Topology .....	14
Lonworks cards VLT 5000/6000 HVAC 78 kbps and 1.25 Mbps .....	16
VLT 2800 Fieldbus cards .....	18
FCD 300 Fieldbus cards .....	20
DMS 300 Profibus card .....	23
Adap-Kool Lon card .....	23
Miscellaneous, Accessories to Fieldbus	
VLT 3000 to 5000 converter software .....	24
Profibus SUB D9 connector .....	25
Fieldbus options ordering number for VLT 5000: .....	26
Fieldbus options ordering number for VLT 6000: .....	27
Fieldbus options ordering number for VLT 8000: .....	27
Previous produce fieldbus cards: .....	28

### ■ Introduction:

This instruction can be used in conjunction with Danfoss Drives High Performance Fieldbus cards. It briefly shows the most important Technical data for each Fieldbus we support. For more information or Technical data please consult the representative Operating Instruction.

The table shows the supported Fieldbusses:

	DMS 300	FCD 300	FCM 300	VLT 2800	VLT 5000	VLT 5000 Flux	VLT 6000 HVAC	VLT 8000 Aqua
Profibus DPV0	✓	⇓	✓	⇓	⇓	✓	⇓	⇓
Profibus DPV1		✓		✓	✓		✓	✓
Profibus FMS					✓ <sup>①</sup>	✓ <sup>①</sup>	✓ <sup>①</sup>	✓ <sup>①</sup>
Interbus					✓ <sup>②</sup>			
DeviceNet		✓		✓	✓	✓	✓	✓
AS-i	✓	✓						
Modbus+					✓			
Modbus RTU		✓ <sup>②</sup>	✓ <sup>③</sup>	✓ <sup>③</sup>	✓	✓ <sup>③</sup>	✓	✓
LonWorks					✓		✓	✓ <sup>④</sup>
FC protocol		✓	✓	✓	✓	✓	✓	✓
Metasys N2				✓			✓	
L&S FLN							✓	

⇓ These products still support Profibus DPV0, but have now been replaced with Profibus DPV1.

① Note that the Profibus FMS card has a new ordering number, see page 26-27.

② Note that the previous Interbus gateway to Profibus is not available anymore.

③ The Modbus RTU needs to be installed in an external box by these products. The box is not included.

④ VLT 8000 Aqua supports only the LonWorks FTP card.

Issued by: John Bargmeyer, DD-OSE  
 Revision: 3.11  
 Date: 2003-08-13

■ Profibus DP V0/V1 card for VLT 5000/6000/8000

This Profibus DP V0/V1 card is only available as a build in, i.e. if the VLT was produce with a Profibus card.

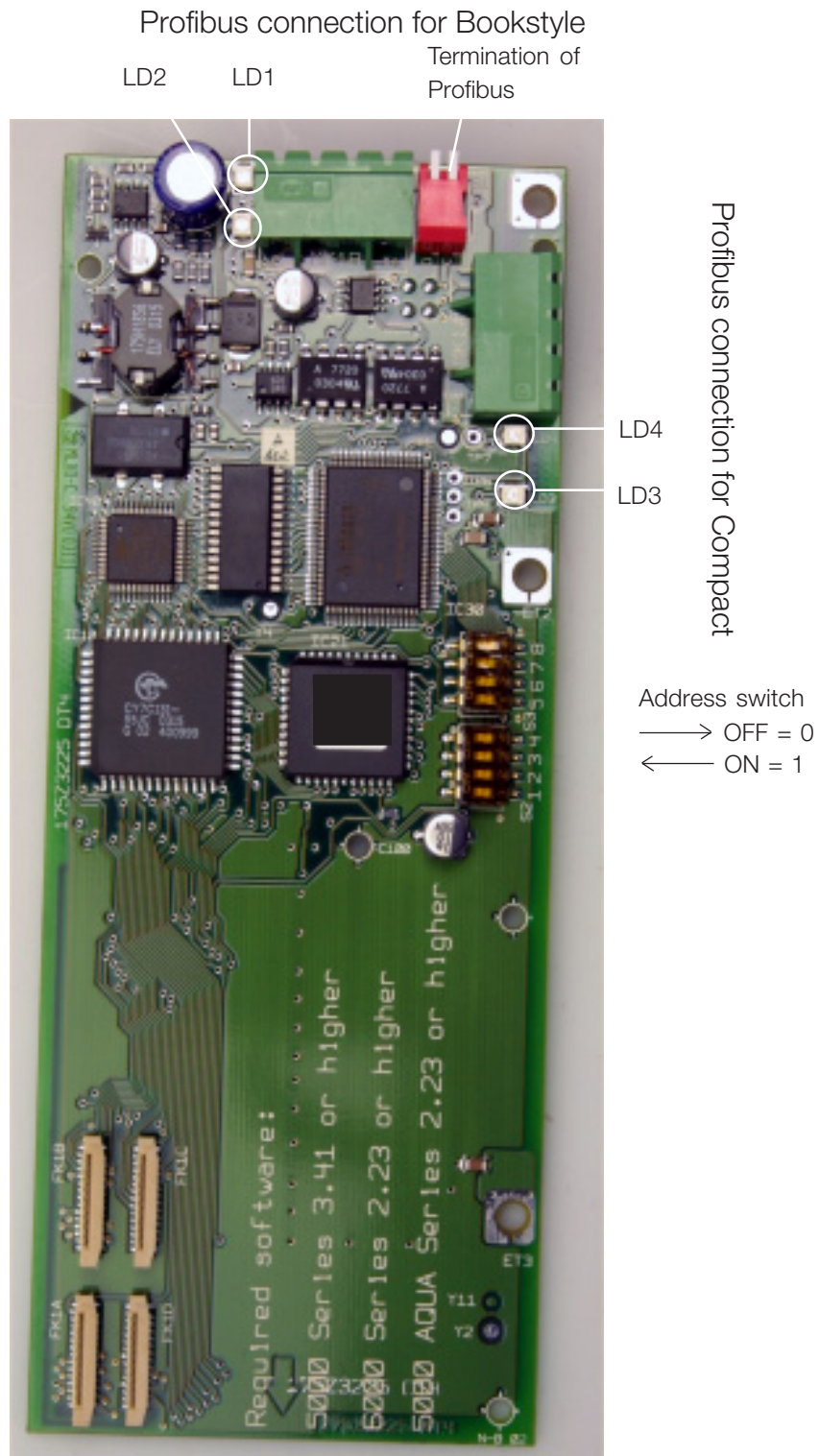

### ■ Profibus DP V0/V1 card for VLT 5000/6000/8000

This Profibus DP V0/V1 card is used in conjunction with a memory card or Sync./Pos card.

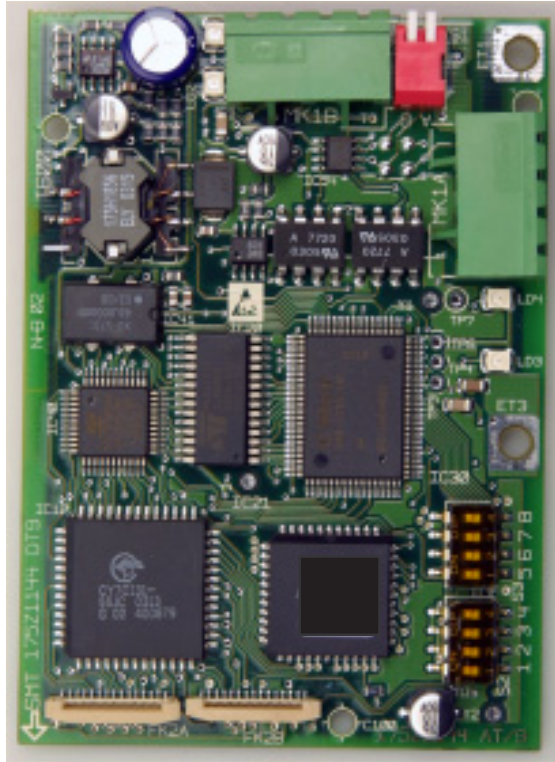

### ■ Profibus DPV0 card for FMS support

This Profibus DPV0 card is available to support installations that use the Profibus FMS protocol.

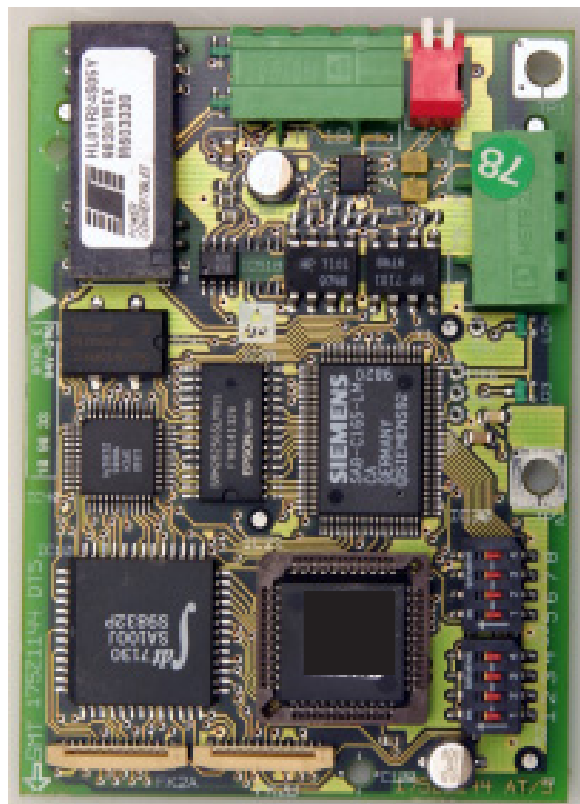

## Profibus data

### ■ Profibus connection

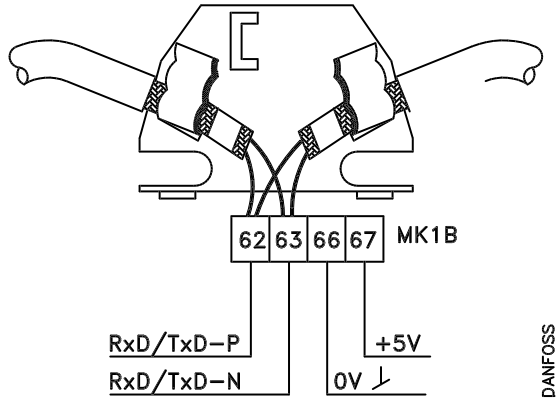

62 = RxD/TxD-P red cable  
 63 = RxD/TxD-N green cable

### ■ Profibus termination

By 'ON' is the bus termination active.

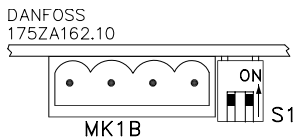

### ■ LEDs

There are 4 LEDs on the PROFIBUS option card:  
 LD1 and LD4: Flashes when the card is communicating.  
 LD2 and LD3: Lights up when the card is initialized and ready to communicate. They will flash while auto baudrate detection is attempting to detect the actual baudrate.

### ■ Cable length

Transmission speed	Max. total cable length [m]
9.6 - 187.5 kBaud	1000
500 kBaud	400
1.5 MBaud	200
3-12 MBaud	100

Note that these cable lengths are for 1 segment with 31 VLT frequency converter.

### ■ Cable specification

- Impedance: 135 to 165 ohm at a measuring frequency from 3 to 20 MHz
- Resistance: < 110 ohm/km
- Capacitance: < 30 pF/m
- Damping: max. 9 dB over the whole wire length
- Cross section: max. 0.34 mm<sup>2</sup>, corresponding to AWG 22
- Cable type: twisted in pairs, 1 x 2, or 2 x 2, or 1 x 4 wires
- Screening: Copper-braided screen or braided screen and foil screen

It is recommended to use the same cable type in the entire network to avoid impedance mismatch.

### ■ Technical data

Baudrate ..... 9.6 - 12000 kBaud  
 Address area ..... 0 - 125

### ■ Profibus literature

Operating Instruction ..... MG.90.G1.02  
 DPV1 Design Guide ..... MG.90.E2.02  
 Siemens S7 PLC ..... MC.50.A2.02  
 Siemens S5 IM 308C ..... MC.50.C1.02  
 SST-PFB-PLC5 Profibus master ..... MN.51.U1.02  
 GE Fanuc Series 90-30 ..... MI.50.X1.02

### ■ GSD files

GSD files are available on the internet at:  
<http://www.danfoss.com/drives>



■ Interbus card VLT 5000

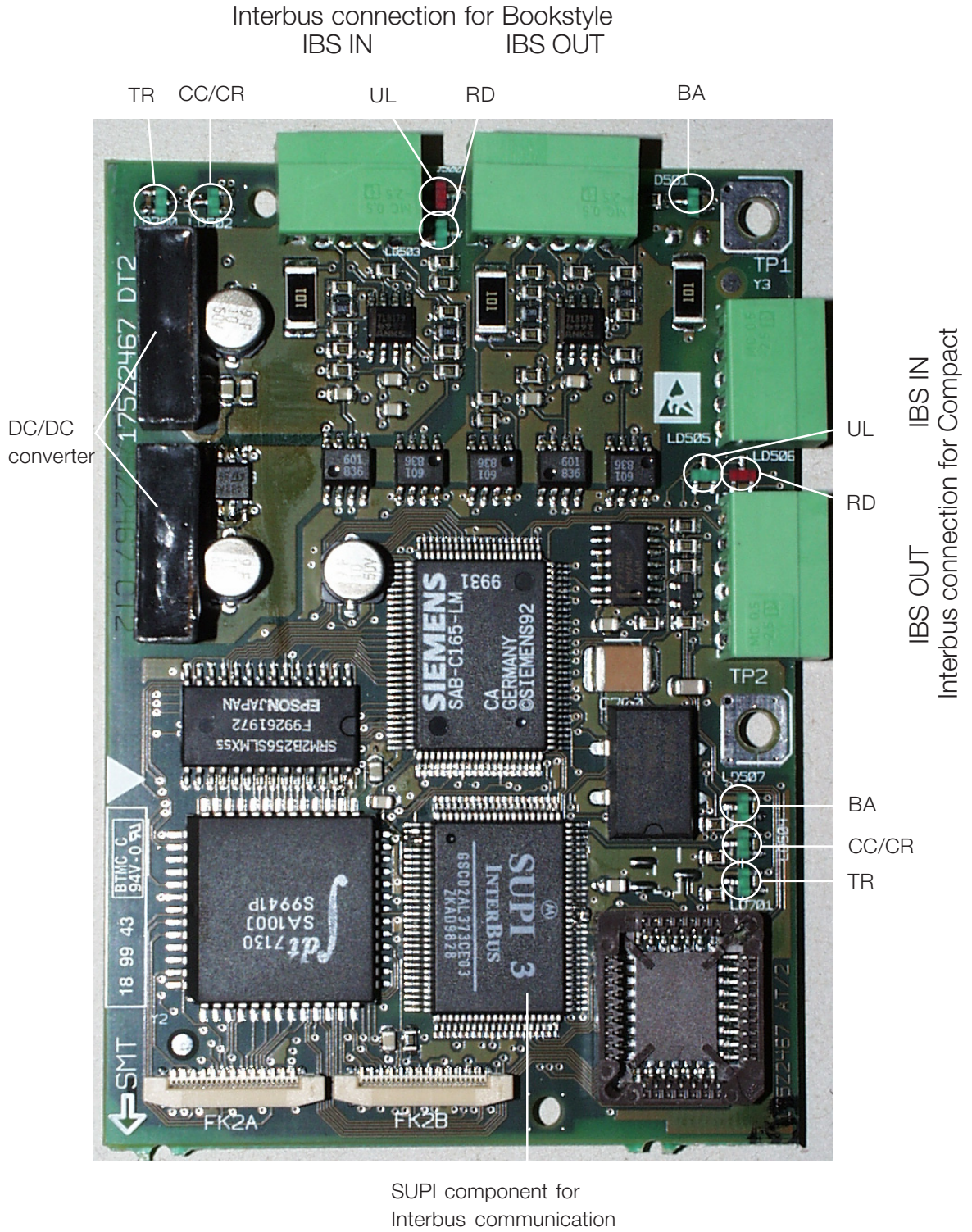

### Interbus data

#### ■ Interbus connection

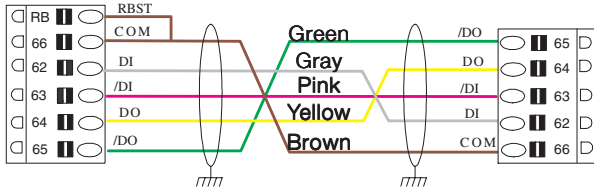

VLT 5000 to VLT 5000

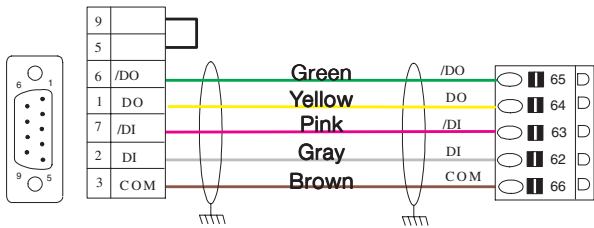

DB9 (male) to VLT 5000

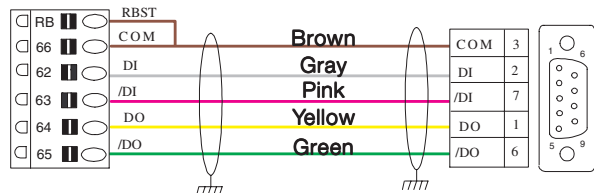

VLT 5000 to DB9 (female)

#### ■ Cable length

Max. total cable length ..... 12.8 km (Cu)

Max. length between nodes ..... 400 m

#### ■ Cable specification

- Impedance: 135 to 165 ohm at a measuring frequency from 3 to 20 MHz
- Resistance: < 110 ohm/km
- Capacitance: < 30 pF/m
- Damping: max. 9 dB over the whole wire length
- Cross section: max. 0.34 mm<sup>2</sup>, corresponding to AWG 22
- Cable type: twisted in pairs, 3 x 2 wires
- Screening: Copper-braided screen or braided screen and foil screen

It is recommended to use the same cable type in the entire network to avoid impedance mismatch.

#### ■ Technical data

Baudrate ..... 500 kBaud

#### ■ LEDs

Name	Indicates	Color	On	OFF
CC/CR:	Cable Check.	Green	Incomming bus active	Incomming bus swiched off
BA	Bus Active.	Green	Bus active	Bus stopped
RD:	Status of outgoing bus.	Red	Outgoing bus stopped	Outgoing bus active
TR:	Transmit/Receive.	Green	PCP Communication running	NO PCP Communication running
UL:	Power OK.	Green	Voltage within permissable range	No Voltage

#### ■ Interbus literature

Operating Instruction ..... MG.10.O2.02

Interbus CMD ..... MN.50.U1.02



■ DeviceNet card for VLT 5000/6000/8000

DeviceNet connection  
for Bookstyle

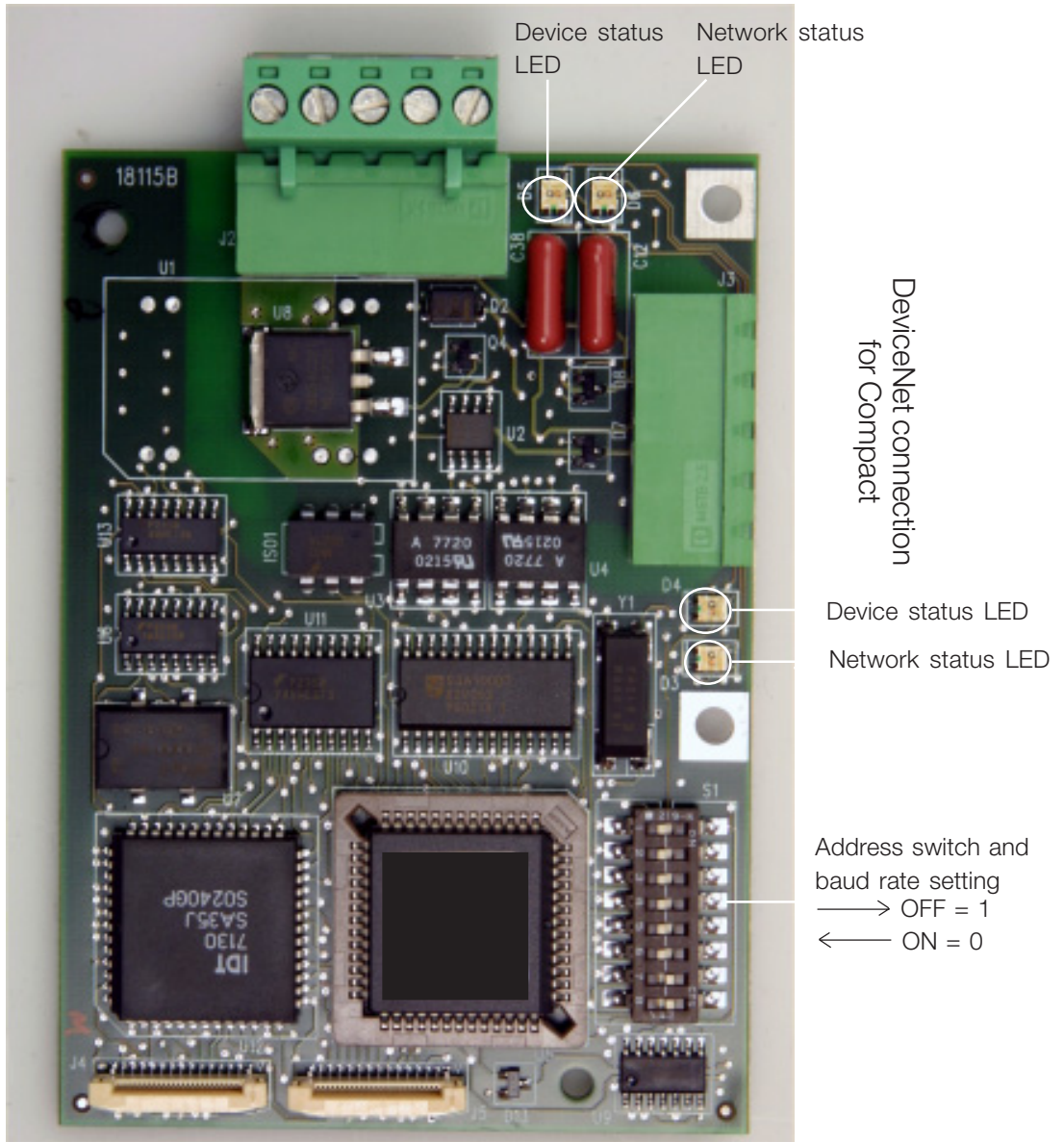

DeviceNet connection  
for Compact

Device status LED  
Network status LED  
Address switch and  
baud rate setting  
→ OFF = 1  
← ON = 0

### DeviceNet data

#### ■ DeviceNet connection

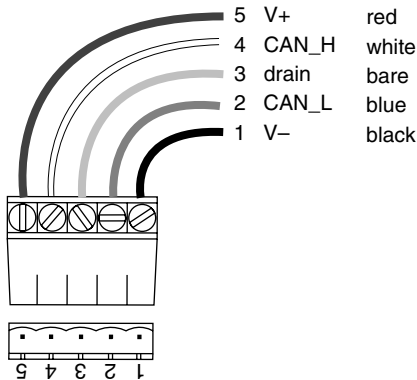

#### ■ DeviceNet termination

Termination resistors should be installed at each end of the bus line.

The resistors shall be mount between terminal 2 CAN\_L and terminal 4 CAN\_H and should have the following specification:

121 Ohm, 1 % Metal film and 1/4 Watt

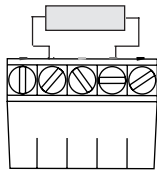

#### ■ LEDs

For the device status LED:

1. when the LED is off, the device is off
2. when the LED is green, the device is operational
3. When the LED is flashing green, the device is in standby
4. when the LED is flashing red, the device detects a minor fault
5. when the LED is red, the device detects an unrecoverable fault
6. when the LED is flashing red/green, the device is self testing

For the network status LED:

1. when the LED is off, the network is non-powered/not online
2. when the LED is flashing green, the network is online but not connected
3. when the LED is green, the network is online and connected
4. when the LED is flashing red, the network has a connection time-out
5. when the LED is red, the network has a critical link failure.

#### ■ Cable length

Transmission speed	Max. total cable length [m]
125 kBaud	500
250 kBaud	250
500 kBaud	100

#### ■ Cable specification

- Cross section: max. 0.78 mm<sup>2</sup>, corresponding to AWG 18
- Cable type: twisted in pairs, 2 x 2 wires with drain wire in center
- Screening: Copper-braided screen or braided screen and foil screen

It is recommended to use the same cable type in the entire network to avoid impedance mismatch.

#### ■ Address and baud rate setting

Dip switch 1-6 set the VLT frequency converters address and 7-8 the baud rate.

If the address shall be set to 3 the dip switches should be set as follow:

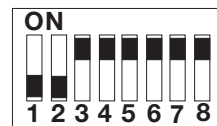

ON = 0  
OFF = 1

Switch Settings for DeviceNet Module Baud Rate:

Baud Rate	Switch Setting 8	Switch Setting 7
125 kBPS	0	0
250 kBPS	0	1
500 kBPS	1	0
125 kBPS	1	1

#### ■ DeviceNet literature

Operating Instruction ..... MG.50.H4.22  
 Allen-Bradley SLC 500 ..... MC.50.D1.02  
 Allen-Bradley Control logix ..... MN.51.T1.02

#### ■ EDS files

EDS files for each product series are available on the internet at:

<http://www.danfoss.com/drives>

■ Modbus+ card VLT 5000 Bookstyle  
Network LED

Top connector

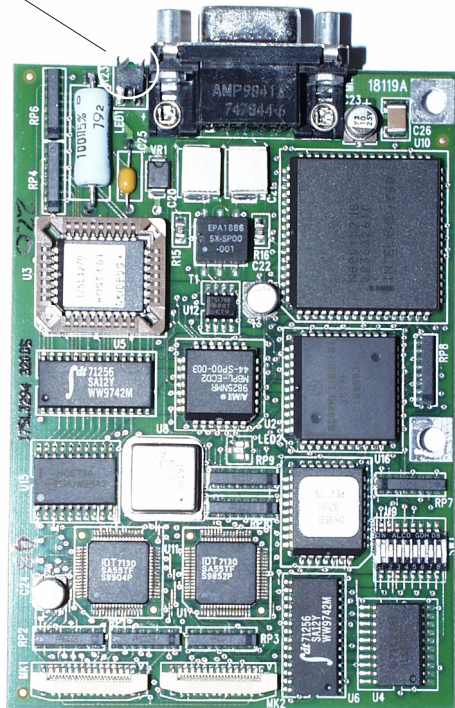

Address switch

■ Modbus+ card VLT 5000 Compact  
Network LED

Network LED

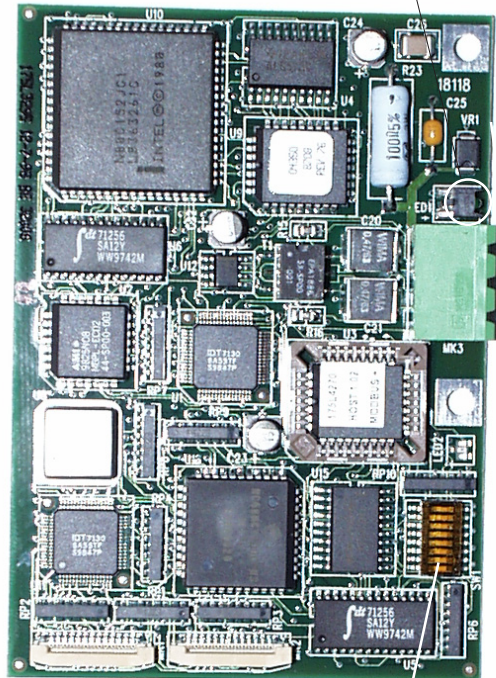

Address switch

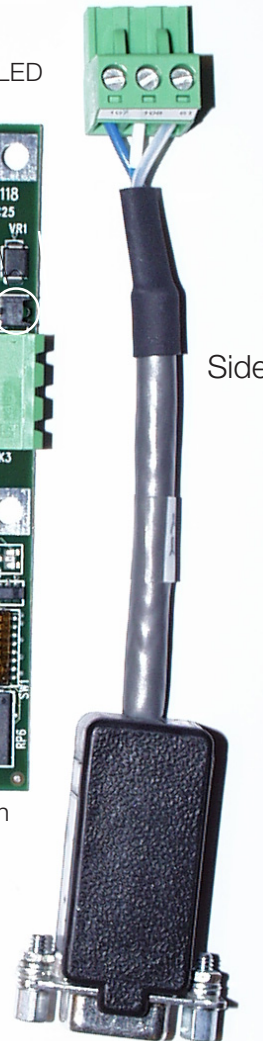

Side connector

## Modbus Plus data

### ■ Modbus connection

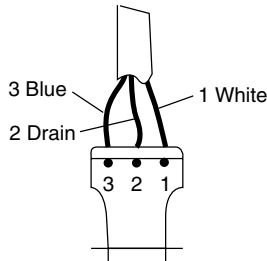

NOTE: Drain wire and shield should be insulated.

### ■ Modbus termination

It is essential that the bus line be terminated properly. A mismatch of impedance may result in reflections on the line that will corrupt data transmission.

The Modbus Plus Option card is provide with a pluggable screw connector for 176F1551 (Compact units) and a DB9 connector for 176F1550 (Book-style units).

An adaptor cable number 190703 is required for use with 176F1551.

Mating network connectors should be ordered from MODICON:

P/N AS-MBKT-085, (1) in-line connector

P/N AS-MBKT-185, (2) terminating connectors

### ■ LEDs

Modbus Plus status is shown by flashing a repetitive pattern on the network indicator (green LED). The patterns are:

- Six flashes per second;  
The node's normal operating state. The node is successfully receiving and passing the token. All nodes on the network should be flashing this pattern.
- One flash per second;  
The node is off-line after just being powered up, or after exiting the four flashes per second mode.
- Two flashes, then OFF for two seconds;  
The node is hearing the token being passed among other nodes, but is never receiving the token. Check the network for an open circuit or defective termination.

### ■ LEDs

- Three flashes, then OFF for 1.7 seconds;  
The node is not hearing any other nodes. It is periodically claiming the token, but finding no other node to which to pass it. Check the network for an open circuit or defective termination.
- Four flashes, then OFF for 1.4 seconds;  
The node has heard a valid message from another node that is using the same address as this node. The node remains in this state as long as it continues to hear the duplicate address. If the duplicate address is not heard for five seconds, the node then changes to the pattern of one flash every second.

NOTE: LED patterns other than those shown above indicate a possible hardware problem.

### ■ Cable specification and length

The recommended Modbus Plus cable is Belden 9841, shielded twisted pair.

Minimum length between nodes ..... 3 m

Maximum length without repeaters ..... 450 m

### ■ Address and baud rate setting

Dip switch 1-6 set the VLT frequency converters address. Dip switch are not 7-8 used.

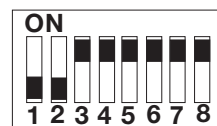

ON = 0

OFF = 1

The address of the VLT frequency converter will be one higher than the binary value. With the above settings of the dip switches the address will be 4.

NOTE: Changes in switch settings are only active after power up.

### ■ Modbus Plus literature

Operating Instruction ..... MG.10.M1.22

Modbus ..... Modbus Plus Tech note



### ■ Modbus RTU card

The Modbus RTU option card is a gateway that translates Modbus RTU telegrams to Danfoss FC protocol. As the FC protocol is integrated in all VLT frequency converters as standard, the Modbus RTU can interface to all our drives except for the DMS 300.

The Modbus RTU can be built into the control cassette of the following products:

- VLT 5000
- VLT 6000 HVAC
- VLT 8000 AQUA

With VLT 5000 Flux, VLT 2800, FCM 300 the Modbus RTU card must be mounted into an external box.

The code number for the Modbus RTU option card is 175Z3362.

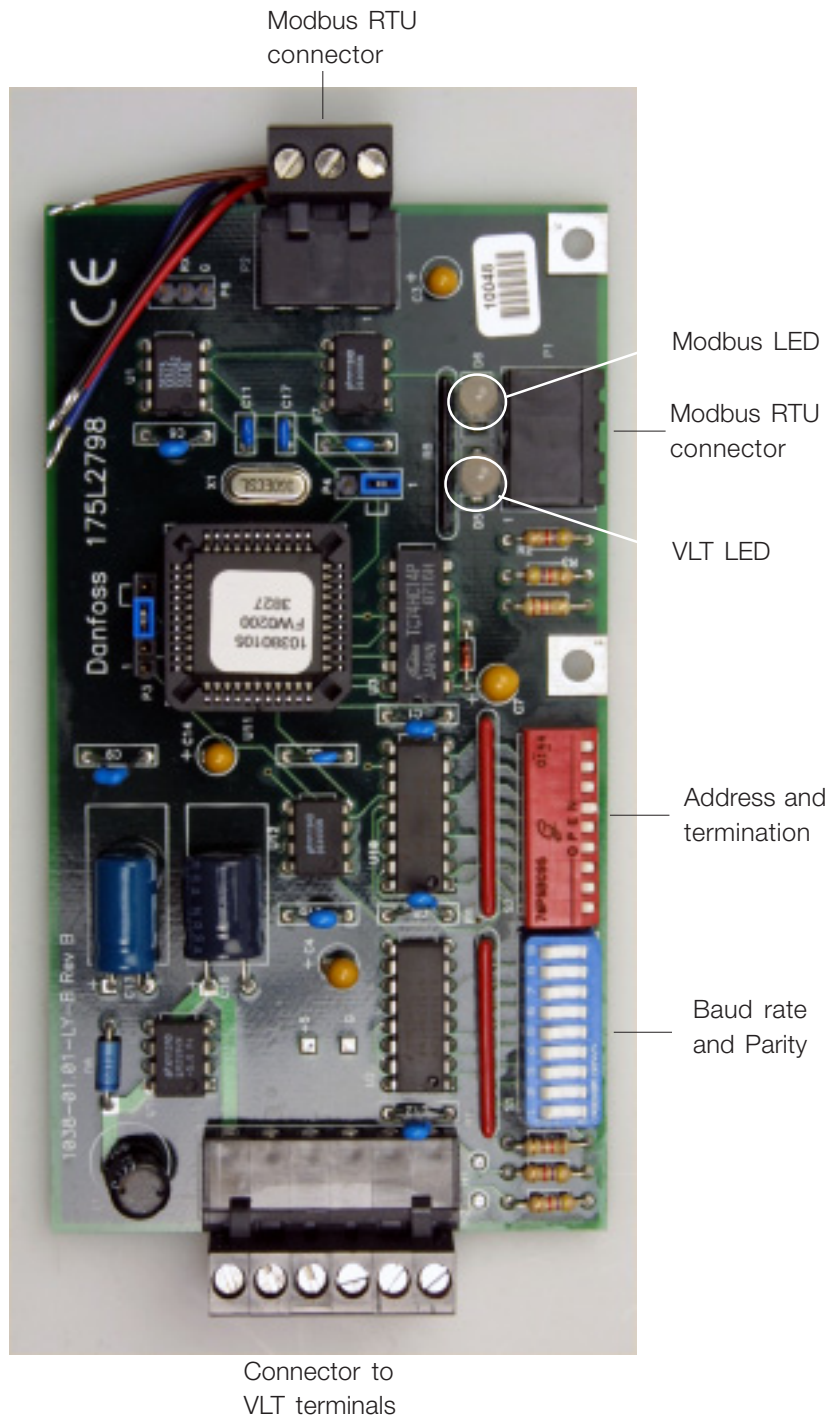

### Modbus RTU data

#### ■ Modbus RTU connection

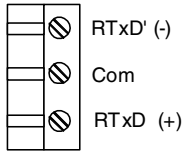

#### ■ Connector from Modbus RTU to VLT

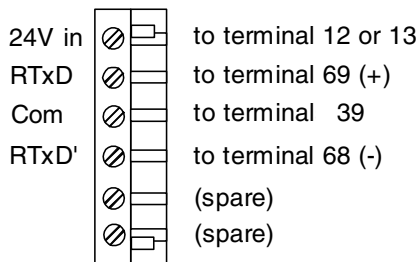

#### ■ LEDs

There are 2 LEDs on the Modbus RTU option card. Both LEDs use the same communication pattern:

- Flashing Green (1 Hz): Communication online (VLT LED) or receiving data (Modbus LED).
- Flashing Red (1 Hz): Communication time out
- Solid Red: Major fault, communication stopped

#### ■ Baud rate and parity Dip switch

This Dip switch sets the baud rate and the parity on the Modbus network.

The baud rate can be set to 4800, 9600 (default) or 19200 baud by switches 1-3.

The parity bit can be set to None, Odd or Even (default) by switches 4-5.

See the Modbus manual for the Dip switch settings. Switches 6-8 are reserved switches.



**9600 Baud Rate and No Parity Switch Settings**

#### ■ Address and termination Dip switch

This Dip switch sets the Modbus address and the termination.

The address can be set by switches 1-8. Default address is 1.

The termination can be set by switch 9. Default termination is ON.

See the Modbus manual for the Dip switch settings.



#### ■ VLT parameter settings

As the Modbus RTU card interface to the built-in RS-485 FC profile the following parameters must be set in the VLT:

##### **VLT 5000/VLT 2800/FCD 300/FCM 300:**

Parameter 500 Address:	001
Parameter 501 Baud rate:	9600 baud
Parameter 512 Profile:	FC protocol

##### **VLT 6000/VLT 8000**

Parameter 500 Profile:	FC protocol
Parameter 501 Address:	001
Parameter 502 Baud rate:	9600 baud

■ Lonworks cards VLT 5000/6000/8000 Free Topology

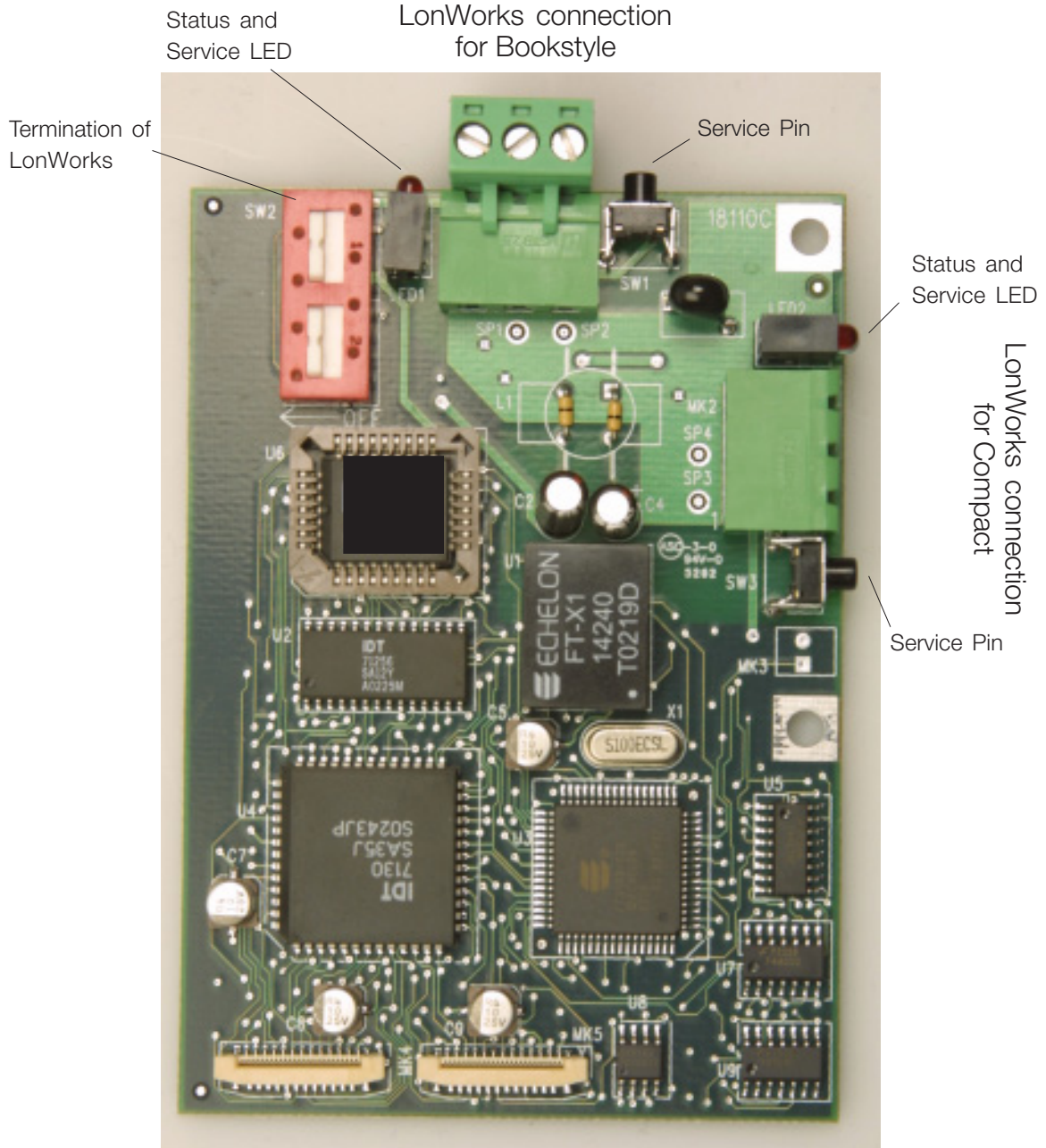

## LonWorks data for FTP

### ■ LonWorks connection

61	
80	Net B 80
79	Net A 79

Connect signal wires to terminal 79 and to 80 of the terminal connector. In free topology model, connections can be reversed.

---

### ■ Lonworks termination

The option card has a termination resistor built-in which is activated by a terminator switch. Use of the terminator is optional, depending upon the network configuration. If termination is provided elsewhere in the network, the termination function should be OFF. Terminator switch position functions are provided in the table below.

Termination	Pos 1	Pos 2
No termination	Net Term Off	Don't Care
Single termination	Net Term On	Net Term Off
Double termination	Net Term On	Net Term On

---

### ■ LEDs

There are 2 LEDs on the LonWorks option card:  
 Green LED: Status LED  
 Red LED: Service LED, see LonWorks manual.

The Status LED patterns are:

#### ON

There is power on the board but there has not been any communication to an input network variable in the last 2 seconds.

#### Flashing 10 times per second

There is regular network communication to the VLT's input network variables.

#### Flashing intermittently

There is network communication to the VLT's input network variables but input network variables are received at a period greater than 2 seconds.

#### Flashing 5 times per second

The response to the network management "Wink" command. The VLT LonWorks node must be reset to leave the wink state.

OFF

No power on board or hardware fault.

---

### ■ Cable length

Free Topology Specifications

	Maximum node-to-node distance	Maximum total wire length
Belden 85102	500 m	500 m
Belden 8471	400 m	500 m
Level IV, 22AWG	400 m	500 m
JY (St) Y 2x2x0.8	320 m	500 m

Maximum bus length for segments with FTT-10 transceivers and with both FTT-10 and LPT-10 transceivers.

	FTT-10 transceivers only	FTT-10 and LPT-10 transceivers
Belden 85102	2700 m	2200 m
Belden 8471	2700 m	2200 m
Level IV, 22AWG	1400 m	1150 m
JY (St) Y 2x2x0.8	900 m	750 m

Danfoss recommends the use of shielded LonWorks communication cable for instance Belden 8719.

---

### ■ LonWorks literature

Operating Instruction ..... MG.60.N1.02  
 LonMaker ..... MI.60.L1.02

---

### ■ Xif files

Xif files are available on the internet at:  
<http://www.danfoss.com/drives>

---



■ Lonworks cards VLT 5000/6000 78 kbps and 1.25 Mbps

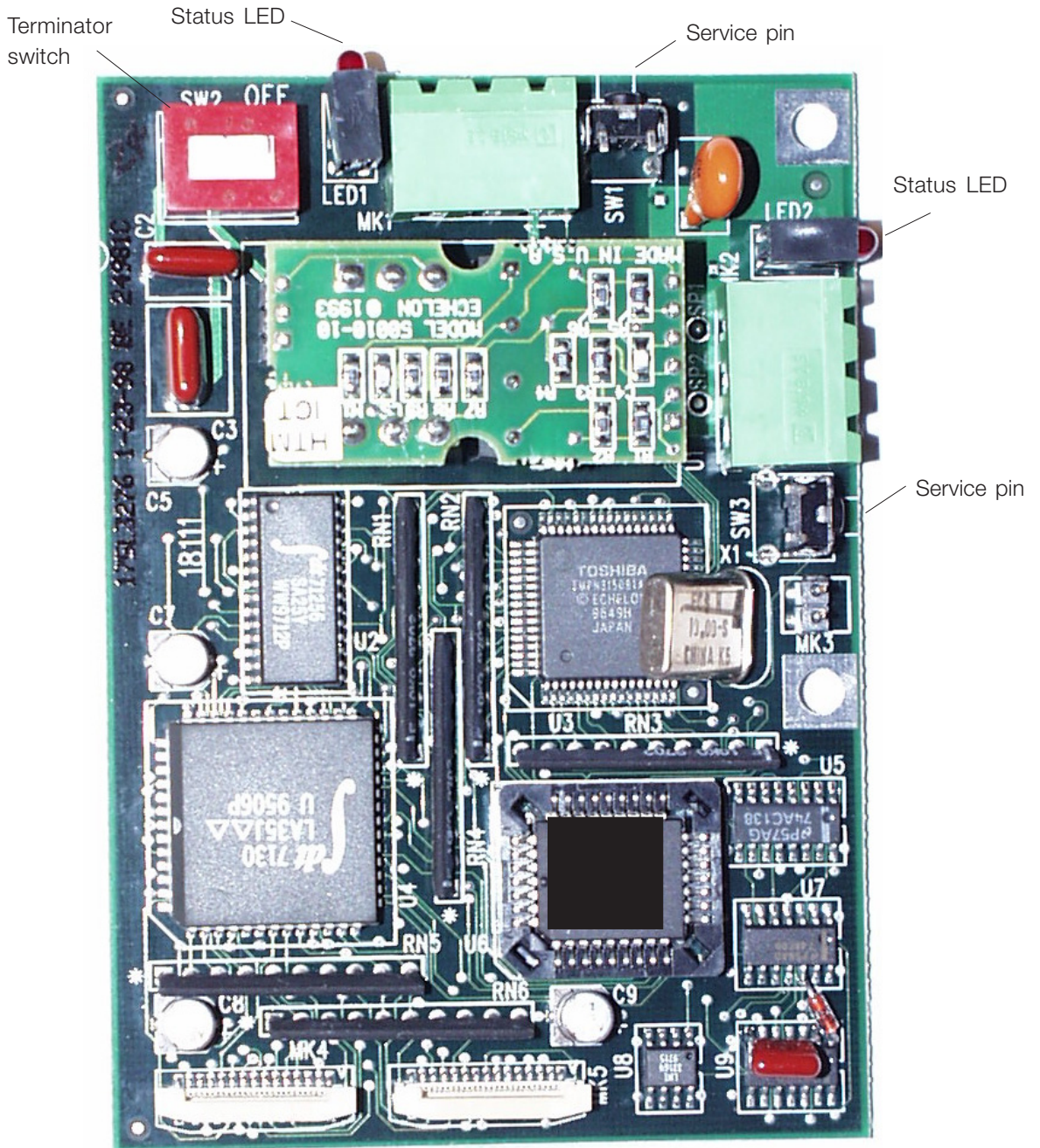

## LonWorks data for 78 kbps and 1.25 Mbps

### ■ LonWorks connection

61	
80	Net B 80
79	Net A 79

Connect signal wires NET A to terminal 79 and NET B to 80 of terminal connector.

---

### ■ Lonworks termination

The option card has a termination resistor built-in which is activated by a terminator switch. Use of the terminator is optional, depending upon the network configuration. If termination is provided elsewhere in the network, the termination function should be OFF. Terminator switch position functions are provided in the table below.

#### Switch 1:

##### Network Termination ON

The VLT LonWorks node is terminated.

##### Network Termination OFF

The VLT LonWorks node is not terminated.

---

### ■ LEDs

There are 2 LEDs on the LonWorks option card:  
 Green LED: Status LED  
 Red LED: Service LED, see LonWorks manual.

The Status LED patterns are:

#### ON

There is power on the board but there has not been any communication to an input network variable in the last 2 seconds.

#### Flashing 10 times per second

There is regular network communication to the VLT's input network variables.

#### Flashing intermittently

There is network communication to the VLT's input network variables but input network variables are received at a period greater than 2 seconds.

#### Flashing 5 times per second

The response to the network management "Wink" command. The VLT LonWorks node must be reset to leave the wink state.

#### OFF

No power on board or hardware fault.

---

### ■ Cable length

78 kbps and 1.25 Mbps Specifications

78 kbps    1.25 Mbps

Network bus length, Typical	2000 m	500 m
Network bus length, Worst case	1330 m	125 m

---

### ■ Cable specification

Network Bus Wiring UL Level IV, 22 AWG (0.65 mm) twisted pair

Network Stub Wiring UL Level IV, 22 or 24 AWG (0.5 mm) twisted pair

Danfoss recommends the use of shielded LonWorks communication cable for instance Belden 8719.

---

### ■ LonWorks literature

Operating Instruction ..... MG.60.E4.02  
 LonMaker ..... MI.60.L1.02

---

### ■ Xif files

Xif files are available on the internet at:  
<http://www.danfoss.com/drives>



■ VLT 2800 fieldbus cards.

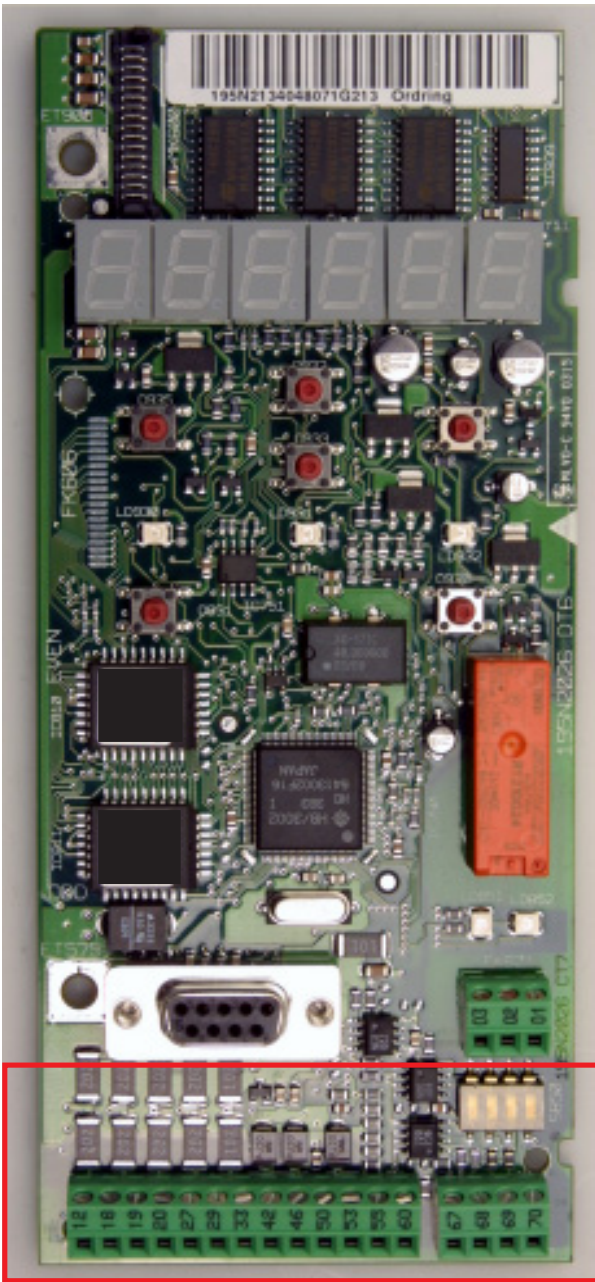

Profibus card



DeviceNet card

Pluggable DeviceNet connector.

### VLT 2800 Profibus card

■ VLT 2800 Profibus connection

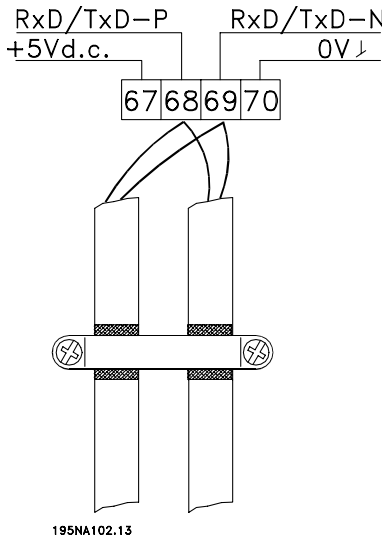

68 = RxD/TxD-P red cable  
 69 = RxD/TxD-N green cable

■ Technical data

Baudrate ..... 9.6 - 3000 kbaud  
 Adress area ..... 0 - 125

■ 12 M baud Profibus card

VLT 2800 can also be delivered with a 12 M baud Profibus control card.  
 Order number: ..... 195N0603

The order number is only for the control card with 12 M baud Profibus. The power part should be order separately.

For other technical data on Profibus, see page 5 *Profibus Data*.

### VLT 2800 DeviceNet card

■ VLT 2800 DeviceNet connection

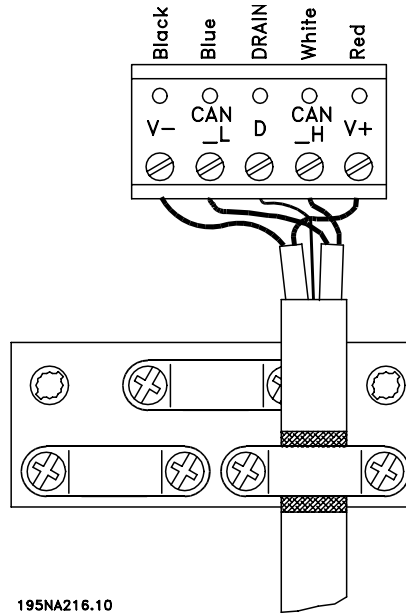

■ Drop cable

An alternative to splicing two trunk lines in the connector on the control card, is using a DeviceNet connection box or a T-connector. For this kind of installation a drop cable is available as an option.

Drop cable ordering number: 195N3113

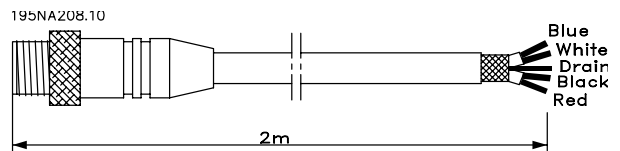

For other technical data on DeviceNet, see page 9 *DeviceNet Data*.



■ FCD 300 Profibus card



Profibus card

■ FCD 300 Profibus connection

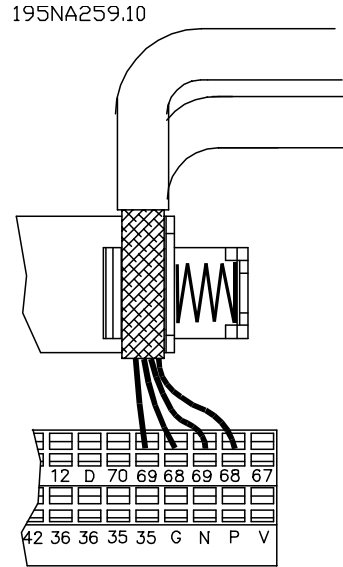

68 = RxD/TxD-P red cable  
69 = RxD/TxD-N green cable

■ FCD 300 DIP switches

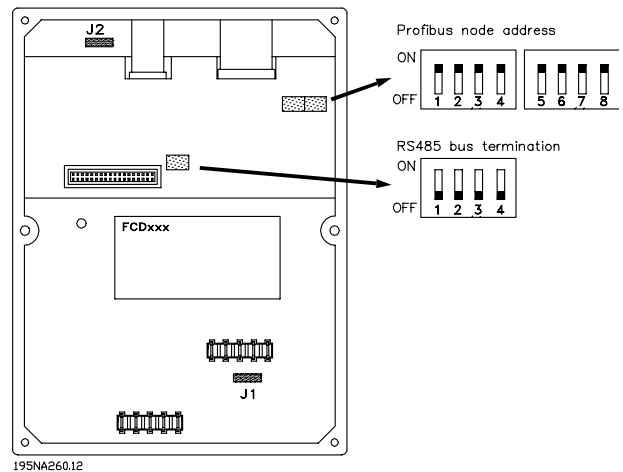

■ FCD 300 DeviceNet card



DeviceNet card

■ FCD 300 DeviceNet connection

Terminal	Colour	Function
67	Red	24 Volt
68	White	Can_high
69	Blue	Can_low
70	Black	GND
D	Bar	Drain

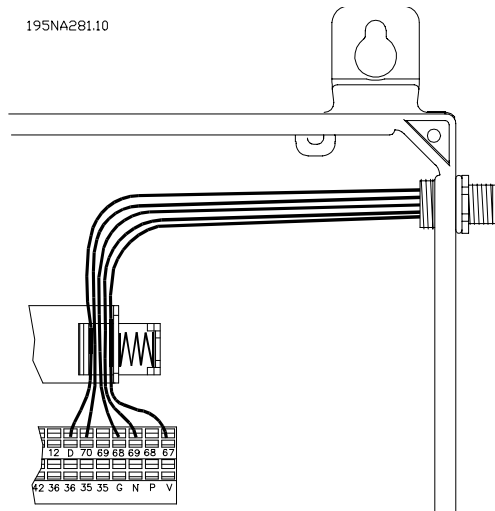

■ FCD 300 Plug 175N2279

The DeviceNet bus connection can be performed through a plug, that is to be mounted in the FCD 300 housing (M16 gland hole) and wired to the inside terminal strip.

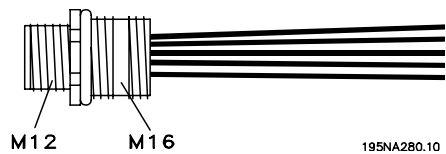

■ FCD 300 AS-i bus card



AS-i bus card

■ FCD 300 AS-i connection

The AS-I bus lines are to be connected to terminals 68 and 69 of the internal terminal strip. A round drop cable can be wired directly into the terminals by using a cable gland. A sealed M12 connector can be mounted into one of the M16 gland holes in the FCD enclosure. The M12 connector is to be wired to the terminals 68, 69 on the control terminal block. The connection is in the following way:

- AS-i + to 68
- AS-i - to 69.

■ FCD 300 AS-i Plug 175N2281

The AS-i bus connection can be performed through a plug, that is to be mounted in the FCD 300 housing (M16 gland hole) and wired to the inside terminal strip.

- Pin 1 (Brown) to AS-i + (68)
- Pin 3 (Blue) to AS-i - (69)

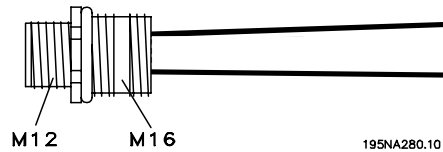

■ DMS 300 Profibus card

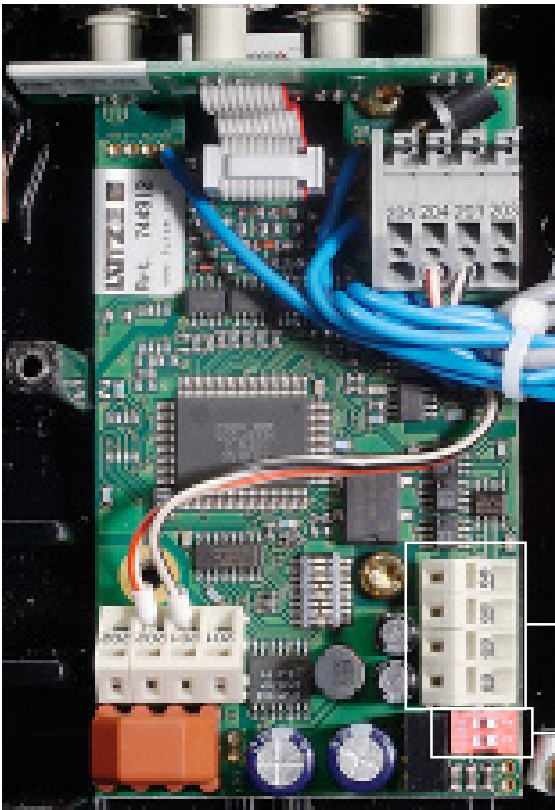

Profibus connection

Profibus termination

■ AKD Lon card

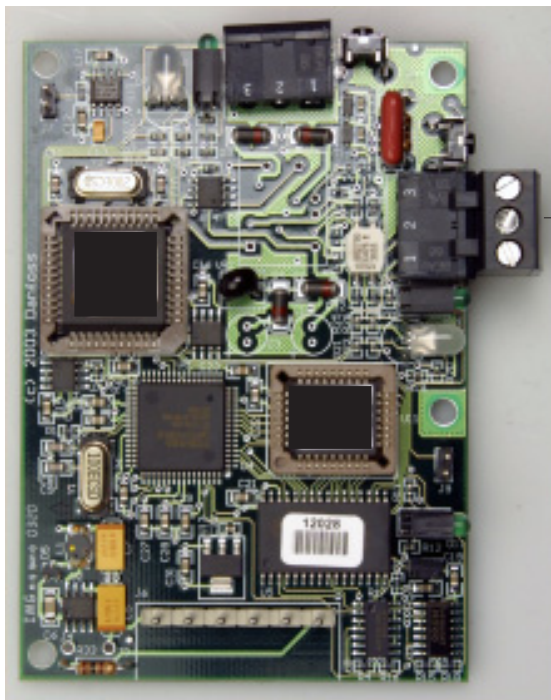

The AKD Lon card can only be used together with AKD 2800 and AKD 5000.

Adap-Kool  
Lon connector

Connector to  
VLT terminals



**■ Miscellaneous, Accessories to Fieldbus**

VLT 3000 to 5000 converter software (17.1x):

The VLT 3000 to 5000 converter is a special software version which is intended to convert a VLT 3000 to a VLT 5000, which replaces the VLT 3000. The converter software is typically used to replace a VLT 3000 with a Profibus interface, but it can also replace a VLT 3000 in a RS-485 network.

With the converter software we only support Profibus DP Norm, so a replaced VLT 3000 should have a software version 3.00 or higher. The software version number can be read out in parameter 603, choice 3.

To purchase (obligatory):

- VLT 5000 ..... 175XXXXX
- Converter software 17.1x ..... 175z3389

Optional:

- Profibus option excl. memory option ..... 175z0402
- Backplate for 5001-5005 Compact IP 20 ordering no. .... 175Z2349
- Separate relay card ..... 175Z1814

If two high voltage relays are needed in VLT 5000 a separate relay card must be purchased.

- Ordering number ..... 176F1814

See also the VLT 3000 to 5000 converter manual MG.50.Q1.02.

---

### ■ Miscellaneous, Accessories to Fieldbus

Profibus kit for SUB D9 connection:

This kit can be mounted together with a VLT 5000/6000/8000 Profibus card and the standard SUB D9 Profibus connector can be used.



Product	Ordering number
VLT 5001-5027 230 V .....	175Z3568
VLT 5032-5052 230 V .....	176F1822
VLT 5001-5102 400 V .....	175Z3568
VLT 5125-5500 400 V .....	176F1822
VLT 6002-6032 230 V .....	175Z3568
VLT 6042-6072 230 V .....	176F1822
VLT 6002-6122 400 V .....	175Z3568
VLT 6150-6550 400 V .....	176F1822
VLT 8002-8032 230 V .....	175Z3568
VLT 8042-8072 230 V .....	176F1822
VLT 8002-8122 400 V .....	175Z3568
VLT 8150-8550 400 V .....	176F1822

By VLT 5072-5102, 6102-6122 and 8102-8122 can the kit first by install from week 36 2003 (G363).

Top connection of Fieldbus by IP 20 Unit:

It is now possible to make a top connection of the Fieldbus cable by all IP 20 units by VLT 5000/6000/8000. The connection will be similar to a book style connection.

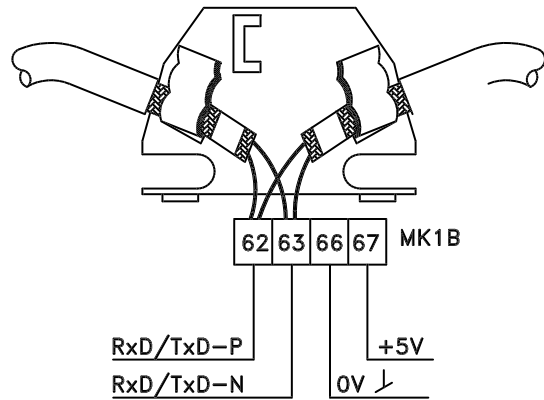

DANFOSS

The top connection can be done on all VLT 5000/6000/8000 IP 20 unit that are produce from the week 15 2003 (G363) except VLT 5032-5052 230 V, VLT 5125-5500 400 V, VLT 6042-6072 230 V, VLT 6150-6550 400 V, VLT 8042-8072 230 V and VLT 8150-8550 400 V.

Top connection on VLT 5072-5102, 6102-6122 and 8102-8122 is available from week 36 2003.

It is also possible to retrofit VLT 5000/6000/8000 IP 20 unit with a clamp (175Z3477), so that a top connection can be done.

In this case the Drive need to be produce after week 23 2002 (G232)



Ordering number 175Z3477

**■ Fieldbus options ordering number for VLT 5000:**
**Profibus DPV1:**

Type	Description	Ordering no.	Ordering no. with conformal coating
Profibus option DPV1	Incl. memory option	175Z0404	175Z2625
Profibus option DPV1	excl. memory option	175Z0402	175Z4363

**Profibus FMS:**

Type	Description	Ordering no.	Ordering no. with conformal coating
Profibus option FMS	Incl. memory option	175Z3722	175Z3723

**Interbus:**

Interbus option	Incl. memory option	175Z3122	175Z3191
Interbus option	excl. memory option	175Z2900	

**DeviceNet:**

DeviceNet option	Incl. memory option	176F1580	176F1581
DeviceNet option	excl. memory option	176F1584	

**Modbus Plus:**

Modbus Plus for Compact units	Incl. memory option	176F1551	176F1553
Modbus Plus for Compact units	Excl. memory option	176F1559	
Modbus Plus for Bookstyle units	Incl. memory option	176F1550	176F1552
Modbus Plus for Bookstyle units	Excl. memory option	176F1558	

**LonWorks:**

LonWorks option, Free topology	Incl. memory option	176F1500	176F1503
LonWorks option, Free topology	excl. memory option	176F1512	
LonWorks option, 78 KBPS	Incl. memory option	176F1501	176F1504
LonWorks option, 78 KBPS	excl. memory option	176F1513	
LonWorks option, 1.25 MBPS	Incl. memory option	176F1502	176F1505
LonWorks option, 1.25 MBPS	excl. memory option	176F1514	

**■ Fieldbus options ordering number for VLT 6000 HVAC:**
**Profibus DPV1:**

Type	Description	Ordering no.	Ordering no. with conformal coating
Profibus option DPV1	Incl. memory option	175Z7800	175Z2905
Profibus option DPV1	excl. memory option	175Z0402	175Z4363

**Profibus FMS:**

Type	Description	Ordering no.	Ordering no. with conformal coating
Profibus option FMS	Incl. memory option	175Z4207	175Z4208

**LonWorks:**

LonWorks option, Free topology	Incl. memory option	176F1515	176F1521
LonWorks option, Free topology	excl. memory option	176F1512	
LonWorks option, 78 KBPS	Incl. memory option	176F1516	176F1522
LonWorks option, 78 KBPS	excl. memory option	176F1513	
LonWorks option, 1.25 MBPS	Incl. memory option	176F1517	176F1523
LonWorks option, 1.25 MBPS	excl. memory option	176F1514	

**DeviceNet:**

DeviceNet option	Incl. memory option	176F1586	176F1587
DeviceNet option	excl. memory option	176F1584	

**■ Fieldbus options ordering number for VLT 8000 Aqua:**
**Profibus DPV1:**

Type	Description	Ordering no.	Ordering no. with conformal coating
Profibus option DPV1	Incl. memory option	175Z3685	175Z3686
Profibus option DPV1	excl. memory option	175Z0402	175Z4363

**LonWorks:**

LonWorks option, Free topology	Incl. memory option	176F0225	-
LonWorks option, Free topology	excl. memory option	176F1512	

**DeviceNet:**

DeviceNet option	Incl. memory option	176F0224	-
DeviceNet option	excl. memory option	176F1584	



### ■ Previous produce Profibus cards

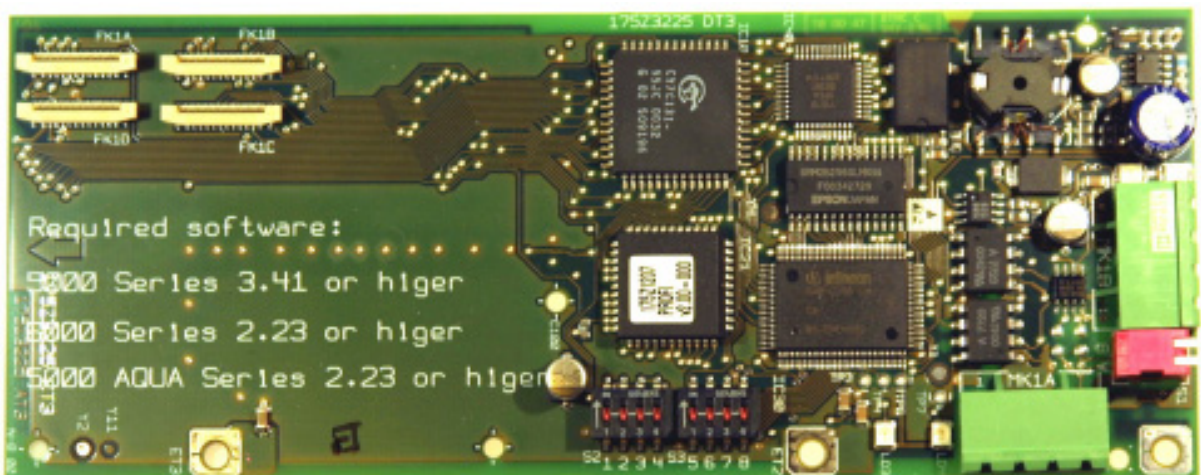
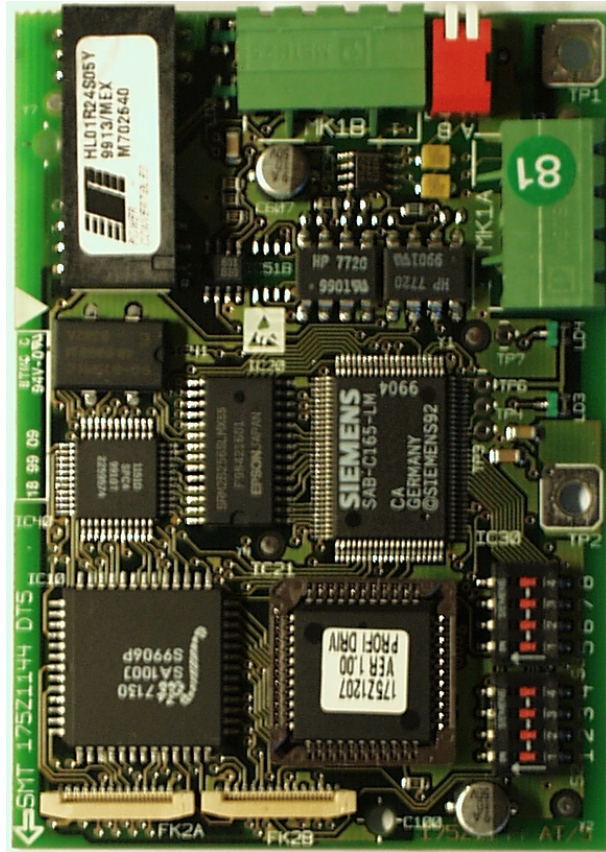

■ Previous produce DeviceNet cards

Revisions number  
18115A

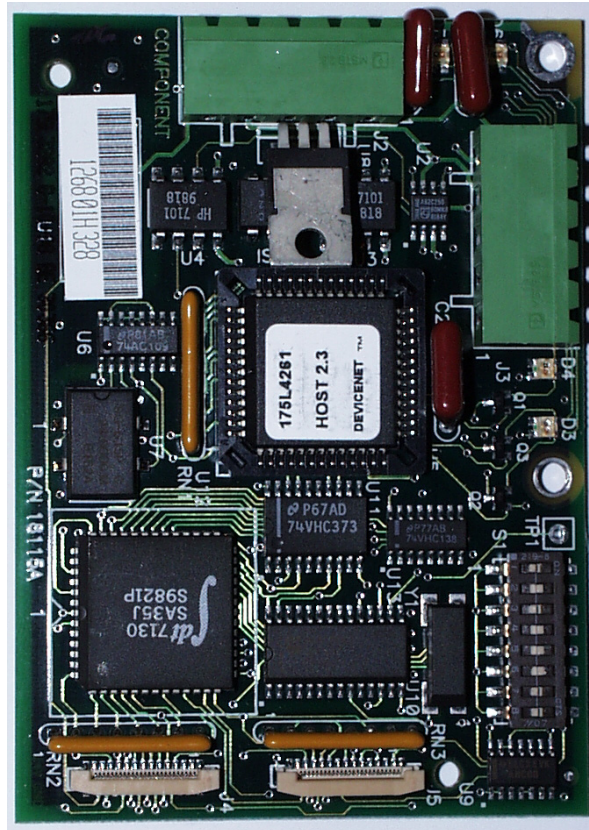

Revisions number  
18115D

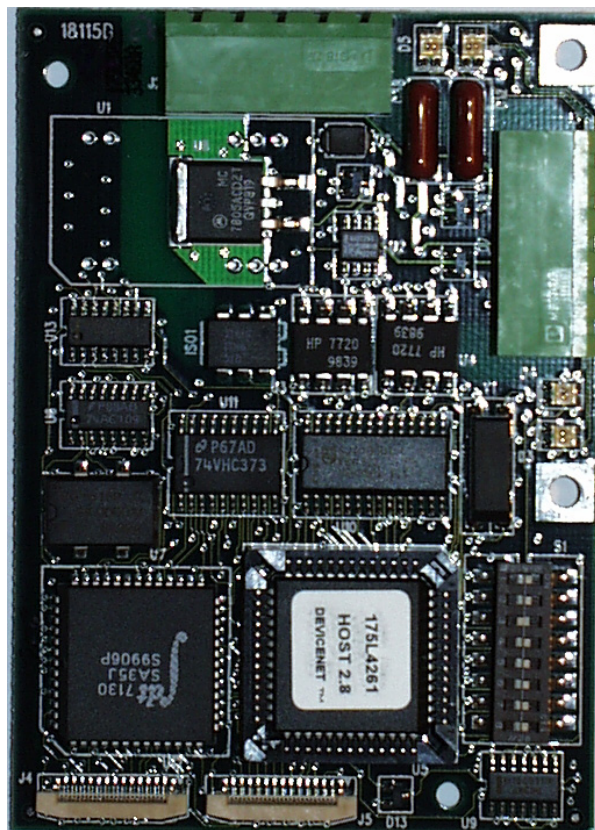



■ Previous produce LonWorks cards

Terminator Switch    Revision number 18110A    Service Pin

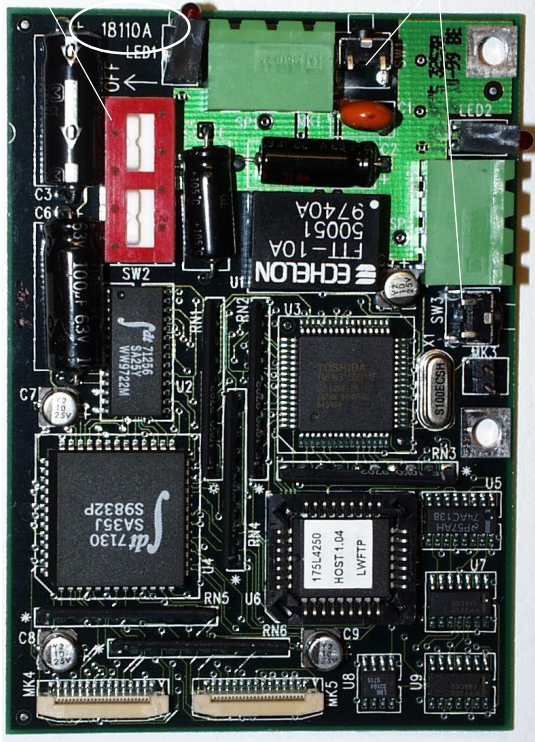

Terminator Switch    Revision number 18110B    Service Pin

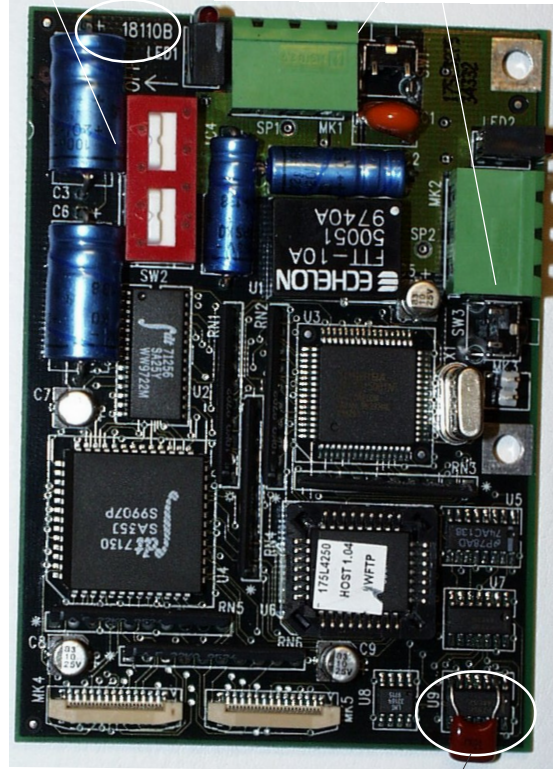

Terminator Switch    This ferrite coil is only mounted on revision C    Revision number 18110C

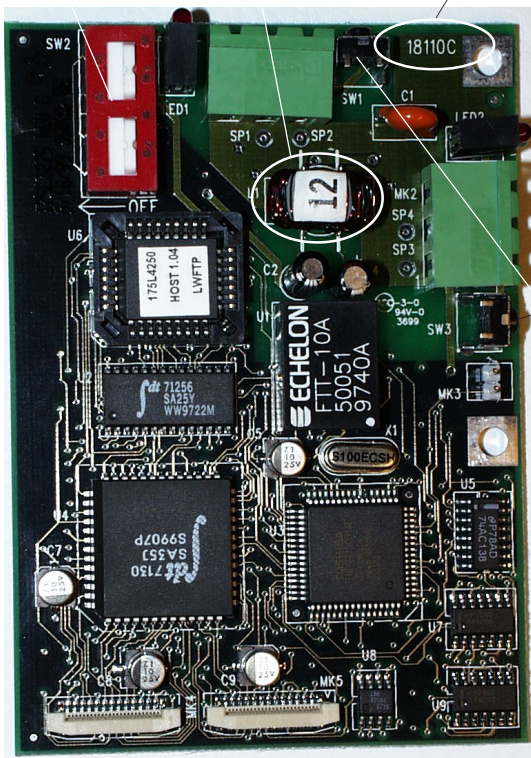

This capacitor is only mounted on revision B. The capacitor can also be mounted on revision A card.

Service Pin

■ Previous produce Modbus RTU cards

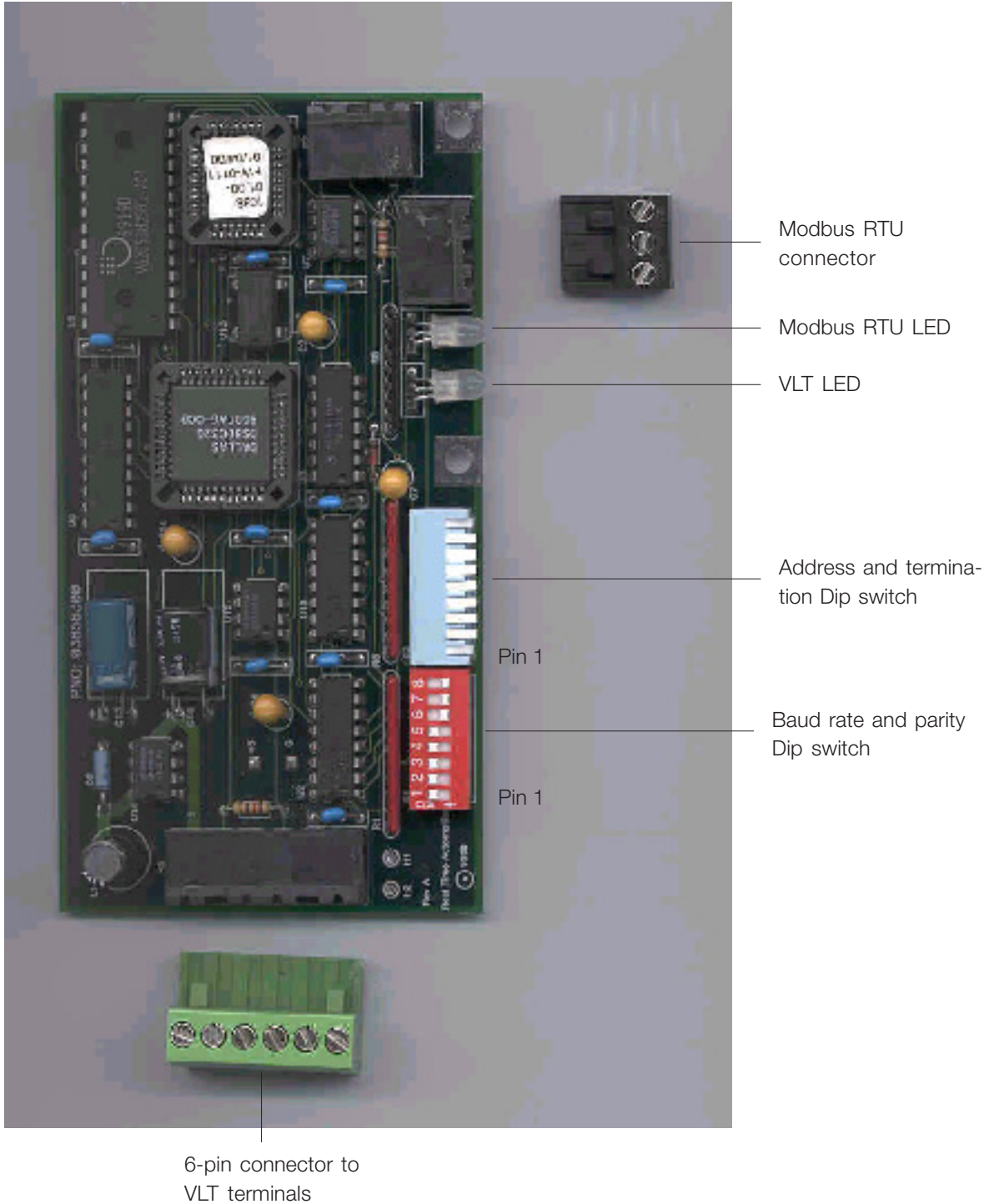



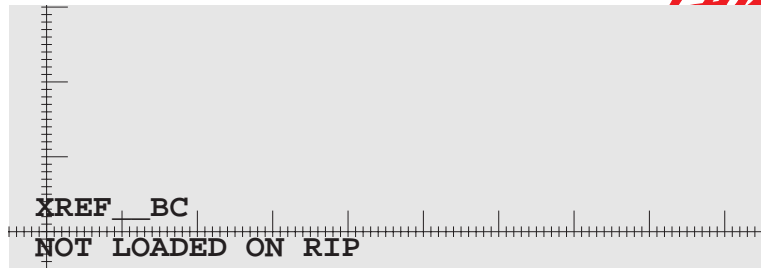

[www.danfoss.com/drives](http://www.danfoss.com/drives)

Danfoss can accept no responsibility for possible errors in catalogues, brochures and other printed material. Danfoss reserves the right to alter its products without notice. This also applies to products already on order provided that such alterations can be made without subsequential changes being necessary in specifications already agreed. All trademarks in this material are property of the respective companies. Danfoss and the Danfoss logotype are trademarks of Danfoss A/S. All rights reserved.

